

CRCA TODAY

SUMMER 2020

The Magazine
of Roofing and
Waterproofing
in Illinois
and Beyond

**Don't Let COVID-19 Distract You From
Implementing Illinois' Required Annual
Sexual Harassment Prevention Training by
December 31, 2020**

Winds of Change in the Windy City

Roof Talk

COVID-19 Cyber Security Risks

**Mobile Crane Safety: Setting up for a
Successful Lift**



Chicago Roofing
Contractors Association

AADVANCED

BUILDING PRODUCTS, LLC

ABP

(800) 498-3975

Proudly Representing the Following Manufacturers

CARLISLE

SYNTEC SYSTEMS

DrexelMetals

Roofing Systems + Custom Fabrication



A **CARLISLE** COMPANY

CARLISLE

ROOF FOAM AND COATINGS

Tom Averitt	President	Cell: 330-592-9109	wtaveritt@advanced.com
Jason Clayton	VP Sales	Cell: 312-805-1919	jrclynton@advanced.com
Frank Arevalo	Outside Sales	Cell: 312-823-7750	farevalo@advanced.com
Dan Klibane	Inside Sales	Office: 330-405-4860	ddkilbane@advanced.com
Jeremy Klabik	Estimator	Office: 330-405-4860	jwklabik@advanced.com



Back Row: Nate Ramser, Dan Kilbane, Ron Holzman, Ed Umbreit, Jeff Smith Front row: Tom Averitt, Jason Clayton, Peri Portman, Dave Flickinger, Jim Wallen, Jeremy Klabik
Not Pictured: Lukas Schmidt, Frank Arevalo, Greg Bush

Chicago Office: 714 Enterprise Dr. Ste. 102 Oak Brook, IL 60523

CRCA TODAY

SUMMER 2020

www.CRCA.org



FEATURES

Adaptability Is the Key.....	5
COVID-19—What Happens Now . . . ?	7
Don't Let COVID-19 Distract You From Implementing Illinois' Required Annual Sexual Harassment Prevention Training by December 31, 2020.....	9
Winds of Change in the Windy City	12
Roof Talk.....	16
COVID-19 Cyber Security Risks	18
Mobile Crane Safety: Setting up for a Successful Lift ...	20
Industry News	22
CRCA Contractor Members.....	31
CRCA Associate Members.....	33

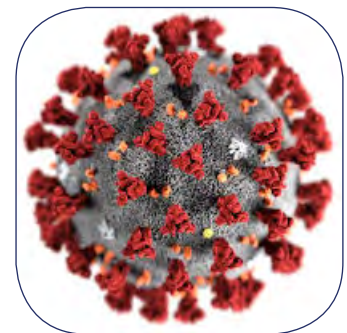

Advertising Contact: Contact CRCA's Office for information at 708-449-3340 or info@crca.org.

Reprints: *CRCA Today* has extra Magazine reprints available to CRCA Members for a limited time, limited quantity, for free. Contact info@crca.org. Reprints are available from CRCA headquarters; 1-100- \$.95/issue; 101-500 - \$.90/issue; 501-1000 - \$.80/issue; 1000+ - \$.70/issue. All shipments FOB 4415 W. Harrison St., Suite 540, Hillside, IL 60162.

Online: Archived *CRCA Today* available at <http://www.crca.org>, Magazine.

On the Cover: The 333 N. Green St., Chicago project was installed by CRCA Contractor Member Combined Roofing Services LLC and included American Hydrotech, Inc. waterproofing and pavers with LiveRoof garden trays. Design by Hitchcock Design Group. Photo courtesy of Combined Roofing Services LLC.

Copyright ©2020, CRCA, Chicago Roofing Contractors Association

CRCA TODAY

SUMMER 2020

CRCA 2020 Board of Directors

Mark Duffy, President
Elens & Maichin Roofing & Sheet Metal, Joliet, IL

Mitch Robin, 1st Vice President
A-1 Roofing Company, Elk Grove Village, IL

Ryan Petrick, 2nd Vice President
Ridgeworth Roofing Co., Inc., Frankfort, IL

Bill O'Brien, Jr., Secretary
Combined Roofing Services LLC, West Chicago, IL

Shawn Sullivan, Treasurer
Olsson Roofing Company, Inc., Aurora, IL

Troy Wormley, Immediate Past President
W.B.R. Roofing, Inc., Wauconda, IL

Jay Adler, Director
Adler Roofing & Sheet Metal, Inc., Joliet, IL

Phil Diederich, Director
Waukegan Roofing Company, Inc., Wheeling, IL

Dominic Dunlap, Director
DCG Roofing Solutions, Inc., Melrose Park, IL

Casey Fraher, Director
Crowther Roofing Roofing & Sheet Metal, Romeoville, IL

Kevin Froeter, Director
Sterling Commercial Roofing, Sterling, IL

Dan Henshaw, Director
G.E. Riddiford, Co., Arlington Heights, IL

Larry Marshall, III, Director
L. Marshall Roofing & Sheet Metal, Inc., Glenview, IL

Mark Moran, Director
Knickerbocker Roofing & Paving Co., Harvey, IL

Jim Prusak, Director
Prusak Construction & Roofing, Inc., Bridgeview, IL

Associate Directors

Joan Crowe, Associate Director
GAF, Downers Grove, IL

Jeff DeJong, Associate Director
Industrial Cork Company, Inc., Elmhurst, IL

Brad Schwab, Associate Director
Schwab Group, LLC, Aurora, IL

Bill McHugh, Executive Director
Chicago Roofing Contractors Association, Hillside, IL

Subscription information:

To subscribe, visit www.crca.org, click on CRCA Today, subscribe. For article submissions, information, contact CRCA at 708-449-3340 or e-mail info@crca.org. To unsubscribe, email info@crca.org, unsubscribe to *CRCA Today*.

CRCA Today, Volume 9, No. 3, is published quarterly by the Chicago Roofing Contractors Association. Information has been obtained from sources believed to be reliable. However, because of the possibility of human or mechanical error by our sources, the Chicago Roofing Contractors Association does not guarantee the accuracy or completeness of any information and is not responsible for any errors or omissions of the results obtained from use of such information. The publisher reserves the right to censor, review, edit, reject or cancel any materials not meeting the standards of *CRCA Today*.

Editorial Contributions: You are invited to share your expertise and perspectives. Before writing, visit www.crca.org / magazine, or contact CRCA at info@crca.org for writing guidelines & policies.



GEMCO
ROOFING & BUILDING SUPPLY
Family Owned & Operated Since 1977

Residential Products & Accessories

- Shingles
 - Skylights
 - Cedar Shakes
 - Slate Tile
 - Synthetic Tile

Gemco has remained a family run business since 1977. Equipped with a knowledgeable staff, we continue to provide superior customer service for all of your roofing needs.

Commercial Products & Accessories

- EPDM
 - Modified
 - PVC
 - TPO
 - Roof Coatings
 - Waterproofing

- Knowledgeable Staff
- Convenient Location
- Same Day & Emergency Deliveries
- Roof Top Deliveries

2601 Van Buren St
Bellwood, IL 60104
(708)544-1444
www.GemcoRoofingSupply.com

ARMOR FLEX™

White

Liquid Silicone

Roof Membrane



- Less waste, more profit
- Faster and easier to install
- Moisture cure for all temperature application
- Pond-Proof Technology eliminates call backs
- Resilient protection from the Weather

www.apoc.com
Contact Elizabeth Seko at (224)806-3195



The Choice of Top Professionals™

Adaptability Is the Key

By Mark Duffy

For the first six months as CRCA President, to say it has been uneventful would be an understatement! 2020 started out normal as usual. A successful CRCA Trade Show & Seminars was put on by the Trade Show Committee and CRCA Leadership in January. CRCA's committees were setup with their visions and goals of what they were looking to achieve for the year.

Then in March, COVID-19 hit. Just as everyone experienced, the CRCA was left with a lot of uncertainty. But that uncertainty quickly changed to adaptation. Between the Board Members, Trustees, Committee Chairs and Committee Members, we jumped quickly into action.

With the help of Frank Marino and the CRCA Safety Committee, we got information to our members to ensure everyone knew what was required for a safe work environment as roofing was considered an essential trade. The Safety Committee was able to accomplish that quickly and continues to provide information to CRCA Membership.

The CRCA Industry Affairs committee was thrown into a battle with the Governor over a Work Comp/ COVID-19 issue. With the help of CRCA legislative consultant Margaret Vaughn, they were able to get a temporary restraining order on an Emergency Workers' Compensation rule that was put into place and then ultimately removed.

Continuing on, we had to decide on what to do with events, venues, and programming. We setup webinars, cancelled events and started planning for our "New Normal". Committees moved forward. Even though the Scholarship Dinner was cancelled, the CRCA Scholarship Committee gave \$10,000 in scholarships to two new deserving individuals as well as \$28,000 to the Chicagoland Roofing Council 2020 recipients. The Building Envelope, Contracts and Insurance,

Health & Safety, Industrial Affairs and Technical Committees have provided content for the webinars and educational information.

The CRCA Contracts & Insurance Committee was enlisted to provide key legal and insurance information, helping members protect their businesses moving forward. The IL mandatory Sexual Harassment Training was provided to members, in English and Spanish.

These are challenging times, but the CRCA will do its best to continue to grow, develop and influence. We are not sure what one month, two months or three months from now will look like, but just know the CRCA will adapt and change as needed as we move forward. 



Mark Duffy, President



TRUSTED
BY THE
BEST

WE'LL LOWER YOUR EXPECTATIONS

ZERO leaks we can't handle

ZERO surprise fees

ZERO tech no-shows

ZERO breach warranty

AT ILD, WE GO OUT OF OUR WAY TO DELIVER THE UNEXPECTED

If you've come to anticipate scheduling delays, budget overruns and unreliable work from your trades, ILD will be a welcome surprise. We guarantee 100% accuracy in detecting membrane breaches. Our technicians are the most highly qualified in the field, giving you results that are on time, every time.

For the highest standards
in leak detection.

Toll Free: 1.866.282.5325
info@leak-detection.com

TRUSTED BY
THE BEST.



COVID-19—What Happens Now . . . ?

Frank Marino, CSP and Philip Hayes



Frank Marino, CSP



Philip Hayes

SARS-CoV-2 (COVID-19) has disrupted all our lives this spring and now summer, and we are not out of the woods yet. The Chicago roofing industry was not spared these effects, and there are still challenges that lie ahead. The state of Illinois has begun reopening, relaxing the existing “stay-at-home” Executive Order, while cases are still popping up around the country. The question that many roofers have is, what happens now?

COVID-19 in Illinois as of 7/15/20

a/o July 15, 2020	Positive Cases	Deaths
Illinois	156,693	7,457
Chicago	55,836	2,701
Cook	97,214	4,750
Lake	10,653	432
DuPage	9,917	494
Kane	8,320	288
Will	7,476	330
Winnebago	3,264	108

Wikipedia data

To begin with, let us take a look back at what we have learned about COVID-19. Deaths in the United States have exceeded 138,000 people. But how does Covid-19 stack up against previous viruses over the past 50 years? Surprisingly, not as bad as you would think.

Fatality rate of major virus outbreaks worldwide in the last fifty years as of 2020.

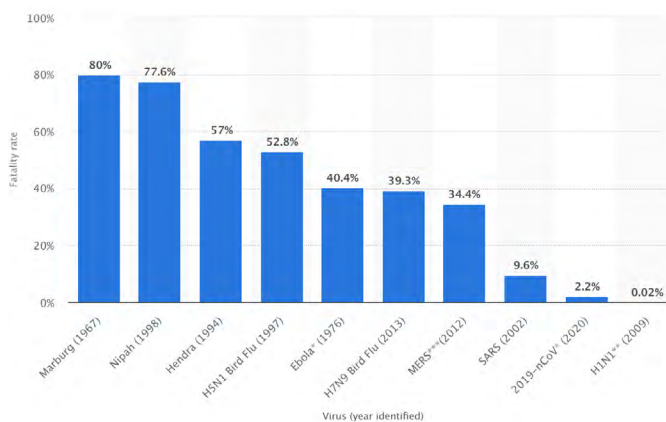

Graph courtesy of statista.com

So, if COVID-19 does not crack the top five deadliest viruses in our lifetime, why is the world having such difficulty getting its arms around the problem? The answer lies in these three simple characteristics:

1. COVID-19 is a “Novel” virus, meaning it has never been seen before.
2. It is highly contagious.
3. People can spread the disease without even knowing they have it (asymptomatic spread).

These three characteristics that make COVID-19 so difficult to control. Recent studies have shown as many as 80% of infected people will be asymptomatic. As more studies are presented and we continue to understand how this virus operates, roofing contractors must stay vigilant on preventing the spread of COVID-19 in the workplace. Back in early April of 2020, OSHA had made an official announcement that COVID-19 is a recognized hazard in the workplace. This was a particularly important development because it was not a guarantee that the Federal Agency would take this position (i.e. the common cold and flu are exempt).

What this means is the OSHA General Duty Clause, Section (5)(a)(1) is enforceable on the roof. The General Duty Clause requires:

Each employer to furnish to each of its employees a workplace that is free from recognized hazards that are causing or likely to cause death or serious physical harm.

The general duty provisions can be used by OSHA only where there is no standard that applies to the particular hazard and the employer has its own employees exposed to the alleged hazard.

All the following elements are necessary for OSHA to prove a general duty clause violation:

1. The employer fails to keep the workplace free of a hazard to which its employees were exposed.
2. The hazard was recognized.
3. The hazard was causing, or was likely to cause, death or serious physical harm.
4. There was a feasible and useful method to correct the hazard.

COVID-19 fits all four of the criteria listed above, and the guidelines laid out by the CDC as well as the existing Illinois Executive Order to build effective safety programs and policies to protect employees. This will be the environment all businesses in Illinois will be working in until OSHA changes its position.

Looking Ahead . . . What Does My Insurance Spend Look Like Due to the COVID-19 Disruption?

With the major disruption COVID-19 has caused in the world, the ripple effect will be significant on the insurance marketplace. Because of the uncertainty, insurance carriers are backing down and tightening restrictions. As mentioned in the webinar, the umbrella liability line of business has been immediately impacted. Carriers who are normally offering large limits of liability are taking risk off the table by pulling back (instead of offering a 10M umbrella, they are only offering 5M). For our members, the impact is a higher annual premium spend.

In addition to the insurance market hardening, the EMR calculation has changed due to COVID-19 in the workplace. For all roofing contractors, keeping the EMR at 1.00 or below is crucial for optimal job placement. Here are a few things to keep in mind as you prepare for your next EMR calculation:

1. EMR is calculated on your prior 3 years' experience NOT including the current year
 - a. 2020 term will not hit your EMR calculation until 2021

2. Payroll and EMR have an **INVERSE** relationship
 - a. As Payroll goes up, EMR goes down / As Payroll goes down, EMR goes up

Even with the uncertainty, the roofing industry has an opportunity to capitalize on the changes that lie ahead. The insurance market is still tasked with writing new business, and the best in class contractors are going to reap the benefits. Carriers will attack clean accounts with below market pricing to hit new business goals. The CRCA membership carries a badge of safety first and best in class operations, so the opportunity is there to take advantage of the volatile marketplace. 

References:

www.osha.gov

<https://www.statista.com/statistics/1095129/worldwide-fatality-rate-of-major-virus-outbreaks-in-the-last-50-years/>

<https://dph.illinois.gov/covid19>

Frank Marino is Vice President at Safety Check Inc., a safety consulting firm in the Chicago area and CRCA Associate Member. Marino has extensive experience in roofing safety and is a co-chair of the CRCA Health and Safety Committee. He is a member of the Occupational Environmental Safety & Health Advisory Board at the University of Wisconsin, working with faculty and safety professionals on curriculum development and industry updates. He can be reached at fmario@safetycheckinc.com.

Philip Hayes is a Risk Management Consultant for CRCA Member firm Esser Hayes. He is a construction vertical practice leader at Assured Partners/Esser Hayes Insurance Group, a full lines insurance brokerage firm. He is a member of both the CRCA Health and Safety as well as the Contracts & Insurance Committee. He represents contractors all over the Chicagoland area with emphasis on the roofing industry. For more information, contact Phil at phayes@esserhayes.com.

Editor's Note: With the onset of the COVID-19 pandemic, CRCA was forced to cancel in-person events and meetings to comply with state and local restrictions. Instead, the leaders of CRCA saw the opportunity to educate members on a broad range of topics, from COVID-19 education and legal requirements, energy code education, air barrier basics and even the mandatory Sexual Harassment prevention training required for all Illinois employees. The article above represents some of the information delivered in the June 4th Webinar presentation by Marino and Hayes. These important and impactful webinars were provided to CRCA members free of charge and the content and audio recordings can be found in CRCA's members only area. Looking for our firm's members only login info or want to learn more about becoming a CRCA Member? Contact info@CRCA.org today!

Don't Let COVID-19 Distract You From Implementing Illinois' Required Annual Sexual Harassment Prevention Training by December 31, 2020

By Carol A. Poplawski



Carol A. Poplawski

Last year the Illinois Human Rights Act ("IHRA") was amended to require employers to provide sexual harassment prevention training before December 31, 2020, and each calendar year after that. With the pandemic dominating the news and businesses facing unprecedented challenges in responding

to it, this requirement could easily be overlooked, but doing so can be a costly mistake in an otherwise tough financial business climate. Here is what contractors need to know and do in order to comply.

Who Must Provide Annual Harassment Prevention Training

All employers with one or more employees working in Illinois must provide training.

Who Must Receive Training

Employers must train all employees, including part-time employees, temporary employees, and interns who work or will work in Illinois. But according to the Illinois Department of Human Rights' ("IDHR") frequently asked questions, the law also applies to employers and employees outside Illinois. Employers both in Illinois and out of state are required to:

- Train employees who work or will work in Illinois.
- Train employees who do not work in Illinois but regularly interact with other employees in Illinois—for example, a supervisor located out of state who supervises employees in Illinois.

The IDHR states that training independent contractors is not required. Yet, the agency said it is "strongly advised" that independent contractors receive training if they work on-site or interact with employees.

What the Training Must Include

Training must be accessible to employees with disabilities and non-English speakers. Additionally, employers must provide training that meets the IDHR's minimum training requirements for all employers. These minimum training requirements must:

- Explain and provide examples of sexual harassment,
- Summarize federal and state law and remedies for victims of sexual harassment, and
- Summarize employers' obligations to prevent and investigate sexual harassment and take prompt corrective action.

Employer Recordkeeping Requirements

Lastly, employers are required to maintain internal paper or electronic records of training compliance and make them available for IDHR inspection upon request.

Employers may include one of the following records to reflect training compliance:

- Certificate of participation;
- Signed employee acknowledgement; or
- Training sign-in sheet.

Employers are required to include the following information in their training records:

- Name of employee;
- Date of training;
- Any of the above issued records of compliance; and
- A copy of all written or recorded materials that include the training and training provider.

When the Training Must Be Provided

The deadline for providing the training is December 31, 2020, and annually by December 31. But the IDHR encourages employers to:

- Train new employees as soon as possible after hire; and
- Retrain employees who have received training from a prior employer. Each employer is responsible for ensuring that training received elsewhere is compliant with the law.

Fortunately, it is now easier for employers to comply with this training requirement because on April 30, 2020, the IDHR released its model sexual harassment prevention training (available on the IDHR website). The model training provides the minimum training standards that employers must provide to their employees. To comply with the IHRA, employers may use the model training at no cost, or modify existing training to meet or exceed these minimum standards. Here are the highlights of that training:

Model Sexual Harassment Prevention Training

The IDHR's model sexual harassment training guidance provides:

- An explanation of sexual harassment consistent with the Illinois Human Rights Act;
- Examples of conduct that may constitute sexual harassment;
- A summary of Federal and State statutory laws concerning sexual harassment, including remedies available to victims; and
- A summary of employer responsibilities in the prevention, investigation and corrective measures of sexual harassment.

Additionally, the IDHR answered a list of frequently asked questions, FAQs for Sexual Harassment Prevention Training, addressing the new requirements and standards for training. The FAQs are available on the IDHR website.

Penalties for Noncompliance

Under the IHRA, any employer that does not comply will be issued a notice to show cause, which will give the employer 30 days to comply. Failure to comply within 30 days will result in the IDHR petitioning the Illinois Human Rights Commission for entry of an order imposing a civil penalty against the employer as follows:

For employer with < 4 employees:

- \$500 for a first offense
- \$1,000 for a second offense
- \$3,000 for a third or subsequent offense

For an employer with 4 or more employees:

- \$1,000 for a first offense
- \$3,000 for a second offense
- \$5,000 for a third or subsequent offense

If existing training does not meet the minimum standards from the model training, employers may want to consider modifying training quickly or using the IDHR model training.

Employers are not required to utilize the model program, but if they choose not to do so, the training they provide must meet the minimum standards of the model program.

Key Takeaways

- Consider whether existing training programs already comply with the minimum requirement published by the IDHR.
- If existing training does not meet minimum standards, consider using the IDHR's model sexual harassment prevention training program as a stand-alone training program or to supplement your existing training programs.
- Consider proactively identifying which personnel should receive training, including individuals who are independent contractors or who do not work in Illinois but regularly interact with employees in Illinois.
- Determine how you will train your workforce—Group classroom, Individualized, Web based, Third Party Provider, etc.
- Provide compliant training no later than December 31, 2020, and annually thereafter by December 31, and keep accurate training attendance records. 

Carol Poplawski, Ogletree, Deakins, Nash, Smoak & Stewart, P.C., has spent her entire career representing the interests of management in all areas of labor and employment law. She is a trial attorney and has litigated hundreds of cases in courts and before administrative agencies.

Poplawski has been lead counsel in hundreds of cases in state and federal courts, covering the full range of employment litigation under laws like the Age Discrimination in Employment Act, Title VII of the Civil Rights Act, the Americans with Disabilities Act, the Fair Labor Standards Act, the Family and Medical Leave Act, and the Illinois Human Rights Act. Her litigation experience has given her a keen insight into the employment relationship which she shares with her clients when counseling, advising and training them on workplace issues.

She is a frequent speaker on workplace issues facing today's employers. Ogletree Deakins has developed a compliant employee training program called It's All About RESPECT. The program consists of on-demand supervisor and employee training that is interactive and easy to use. Trainees utilize learning management software, which makes it possible to train on mobile devices including smart phones and traditional workplace computers. For more information on this product, contact Carol at carol.poplawski@ogletree.com or (312) 558-1244.

The Strongest Grip in Residential Roofing.

WIP GRIP

WATER & ICE PROTECTION

PREMIUM SHINGLE UNDERLAYMENT

WIP GRIP is a 55-mil flexible rubberized asphalt, fiberglass-reinforced membrane used as a shingle underlayment on critical roof areas such as eaves, ridges, valleys, dormers and skylights. WIP GRIP underlayment protects roofing structures and interior spaces from water penetration caused by wind-driven rain and ice dams and may also be used as covering for the entire roof to prevent moisture or water entry.

Premium Shingle Self-Adhering Roofing Underlayment

Features and Benefits (includes all of the features & benefits of WIP 100, plus):

- Superior slip-resistance on wet and dry applications for safe and easy installation
- No more tracking
- Adds strength in vulnerable areas, including penetrations, valleys, and over plywood clips
- At the time of eventual re-roof, the proprietary film surface helps to prevent the embedding of shingles to underlayment, providing for easier tear-off



888.717.1440 • www.carlislewip.com

CARLISLE
WIP PRODUCTS

Carlisle and WIP are trademarks of Carlisle. © 2020 Carlisle.



Winds of Change in the Windy City

Chicago's New Building Code Affects Low-Slope Roof System Design

By Joan Crowe, AIA



Joan Crowe, AIA

The 2019 Chicago Building Code, Title 14B (2019 CBC) takes effect on buildings permitted on or after August 2020. With the code requirements in the new 2019 CBC, roofing professionals are faced with using a new standard to determine wind uplift pressures for roof systems.

The 2019 CBC is based on International Code Council's 2018 edition of the International Building Code (2018 IBC). 2018 IBC references the 2016 edition of the American Society of Civil Engineer's standard ASCE 7, "Minimum Design Loads and Associated Criteria for Buildings and Other Structures" (ASCE 7-16). The purpose of this article is to give a broad overview of the changes and the significant issues roofing contractors should be aware of.

What's the Big Deal?

This switch to ASCE 7-16 is disconcerting to the Chicagoland roofing community for a couple of reasons. First, the 2018 and earlier versions of the Chicago Building Code prior to the 2019 CBC based their wind design on the 1982 edition of ANSI-A58.1, "The American National Standard Minimum Design Loads for Buildings and Other Structures." Yes, you read that right, the city was using a standard that was almost 40 years old!

Second, the procedures for determining wind loads were fairly simple for roofing systems. Roofing sheathing and membranes were to be designed for outward pressures found in Table 13-52-310, Minimum Design Wind Pressures—Buildings and Portions Thereof. The values in the table were based on building height and were adjusted by specified percentages for the field and perimeter areas. The width of the perimeter was equal to

10 percent of a building's width and corner zones were not addressed.

This is definitely not the case with the new standard for wind uplift, ASCE 7-16. The calculations involve additional design considerations and the roof zone layouts are way more complex.

ASCE 7-16

ASCE 7 provides methods for determining dead, live, soil, flood, tsunami, snow, rain, atmospheric ice, earthquake, and wind loads, and their combinations for general structural design.

Three editions of ASCE 7 are used in the U.S., the 2005, 2010 and 2016 versions of the document. With each edition, the standard added more complexity and confusion, especially with the 2016 edition.

The following are some of the noteworthy issues and concepts related to ASCE 7-16.

Design Methods

All editions of ASCE 7 provide two methods for structural design, Allowable Stress Design (ASD) or Strength Design (typically called Ultimate Design). Either method may be used, but roof systems are typically designed using ASD. A very common issue is that design wind uplift pressures are often given as Ultimate Design values. This is because the basic wind speed maps in ASCE 7-16 are based on Ultimate Design. These values may be converted to ASD values by using an adjustment factor of 0.6. The applicability of using the ASD method with roof systems and the 0.6 adjustment factor is specifically addressed in Chapter 15 of the building code and ASCE 7-16's commentary.

Keep in mind when using the ASD method, it is accepted engineering practice to use a safety factor of 2.0. The safety factor may be applied to the calculated design wind uplift pressures or it is taken into account when determining a roof assembly's wind rating.

Roof Zone Layouts

For roofing contractors, there will be a big learning curve when dealing with ASCE 7-16's new roof zone layout for low-slope roofs (slopes less than 1½:12) on buildings less than or equal to 60 feet high. ASCE 7 defines a building's height as the distance from the ground surface adjacent to the building to the roof eave line. If the height of the eave varies along the wall, the average height can be used.

ASCE 7-16 added a new zone and it presents the potential to have four roof zones: "interior" field, "exterior" field, perimeter and corner. Additionally, the corner zones are "L-shaped." ASCE 7-16 also revised how the dimensions of the zones are sized from previous editions; they are based on a building's height. See Figure 1.

For rectangular roof plans, ASCE 7-16 describes four possible scenarios for roof zone layout and it depends on the ratios of the building's width and length dimensions to the building height, see Figure 2.

It is also important to note that Zone 1' won't always exist. To illustrate this, see Figures 2, 3, 4 and 5 for examples of a rectangular roof plan (100 ft. by 200 ft.) at varying building heights of 15, 30, 45 and 60 ft.

For buildings taller than 60 ft., the roof zone layout did not change, and actually, it has been the same configuration in the last three editions of ASCE 7. The width of Zones 2 and 3 (perimeter and corners) is 10 percent of the building's width or 3 ft. minimum. The length of Zone 3 is twice that dimension. See Figure 7.

External Pressure Coefficients

These are the values used to determine the wind uplift pressures for the different roof zones. The values for buildings equal to or less than 60 ft. in height went up in ASCE 7-16 compared to the 2010 edition of ASCE 7. However, no changes for buildings taller than 60 ft. See the table below for a comparison.

Zone	External Pressure Coefficients		
	h ≤ 60 ft.		h > 60 ft.
	ASCE 7-10	ASCE 7-16	ASCE 7-10 & ASCE 7-16
1' (interior field)	Not applicable	-0.9	Not applicable
1 (exterior field)	-1.0	-1.7	-1.4
2 (perimeters)	-1.8	-2.3	-2.3
3 (corners)	-2.3	-3.2	-3.2

Mechanically Attached Systems

ASCE 7-16 will have a big impact on mechanically attached single-ply roof membranes installed on buildings equal to or less than 60 ft., especially how perimeter and corner zones are treated. A widely accepted practice is to use "prescriptive enhancement" in these areas. This approach originates from FM Approvals Loss Prevention Data Sheet 1-29, *Roof Deck Securement and Above-Deck Roof Components*.

With the prescriptive enhancement approach, a wind rated roof assembly that meets the wind uplift resistant pressures is selected and the required fastening pattern is used in the field of the roof (Zone 1). To compensate for the increased wind pressures in the perimeter and corner zones, the spacing between fastener rows is reduced. This is accomplished by using half-sheets around the perimeter of the roof or a.k.a., "picture framing" a roof. See Figure 8. Traditionally, this typically meant one or two rows of half sheets for buildings 60 ft. high or less. With ASCE 7-16, a 60 ft. tall building has a perimeter zone width of 36 ft. and this translates into eight rows of 5 ft. wide half sheets.

2018 CBC Vs. 2019 CBC

Let's see how the new building code affects roof system selection by looking at a 100 ft. by 200 ft. rectangular office building as a low-rise (60 ft.) and high-rise (500 ft.) building located in the West Loop. For this comparison, the tables on page 14 show wind uplift pressure values for the field, perimeter and corner zones, but remember that the two editions use different roof zone layout configurations.

Building Height = 60 ft.

Zone	2018 Chicago Building Code		2019 Chicago Building Code (ASCE 7-16)	
	Wind Uplift Pressures (includes a SF=2)	FM RoofNav Assembly	Wind Uplift Pressures (with a SF)	FM RoofNav Assembly
Field	-30 psf	1-60	-48 psf	1-60
Perimeter	-60 psf	1-60	-63 psf	1-75
Corner	-60 psf	1-60	-86 psf	1-90

Building Height = 500 ft.

Zone	2018 Chicago Building Code		2019 Chicago Building Code (ASCE 7-16)	
	Wind Uplift Pressures (includes a SF=2)	FM RoofNav Assembly	Wind Uplift Pressures (with a SF)	FM RoofNav Assembly
Field	-42 psf	1-60	-74 psf	1-75
Perimeter	-84 psf	1-90	-116 psf	1-120
Corner	-84 psf	1-90	-158 psf	1-165

As expected, the wind uplift pressures are higher using ASCE 7-16, especially with the high-rise building. However, please keep in mind that these examples are based on two buildings with specific design parameters. The purpose of this exercise was to give a general sense on how the 2019 CBC affects the wind design values.

(It is important to note that this example refers to FM-rated roof assemblies which can be found using FM Approvals' RoofNav. There are other listing services available to look-up wind-rated roof assemblies, such as UL's Product iQ or SRPI's Directory of Roof Assemblies. Contractors also have the option to contact manufacturers for information on their tested roof assemblies.)

One Last Point

The 2019 CBC has a requirement that did not exist in older versions of the Chicago Building Code, and it should significantly assist roofing contractors. Section 1603.1.4—Wind Design Data - requires the following information be provided in the construction documents:

- Basic design wind speed and allowable stress design wind speed
- Risk category
- Wind exposure
- Applicable internal pressure coefficient
- Design wind pressures to be used for exterior component and cladding materials not specifically designed by the registered design professional responsible for the design of the structure

Therefore, if you do not see wind design data on the drawings and/or in the project specifications—construction documents - go back to the designer of record and notify them that it is a code requirement to provide this information. With the new code in town, it is critical that roofing contractors be given all the information they need to correctly bid and install a roof system that is code compliant. 

All graphics courtesy of GAF

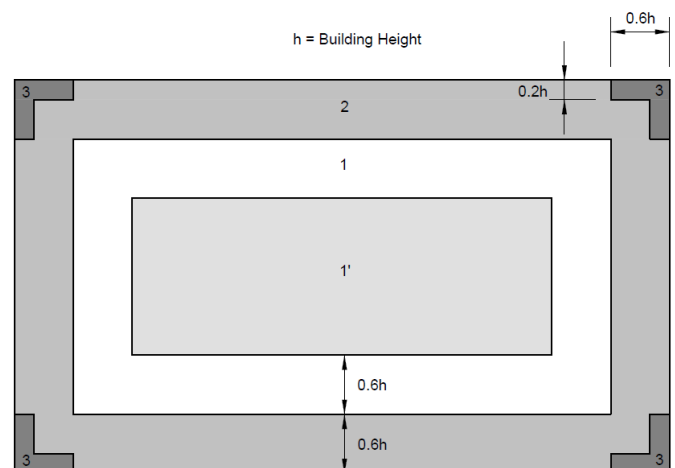

Figure 1: Roof zone layout for low-slope roofs on buildings ≤ 60 ft.

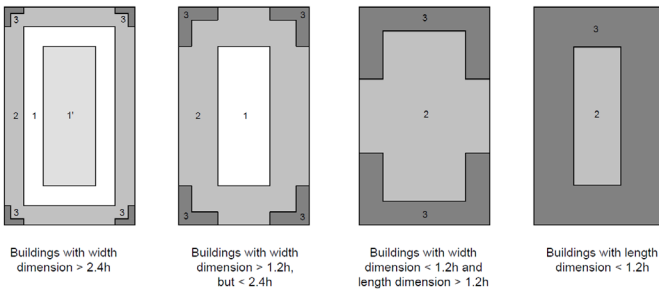

Figure 2: Potential for different roof zone layouts

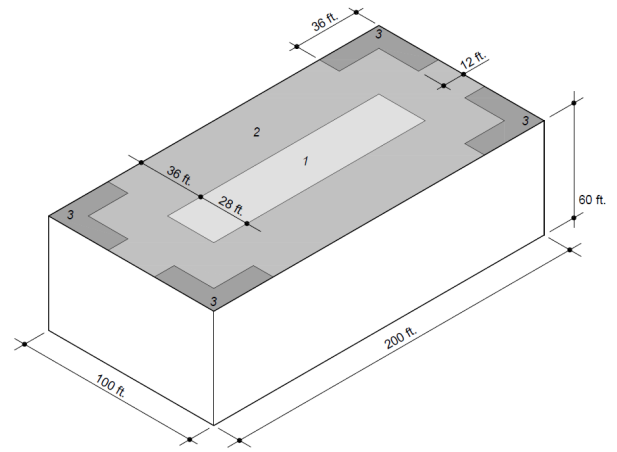

Figure 6: Example of a 100 ft. by 200 ft. roof zone layout for a building 60 ft. high

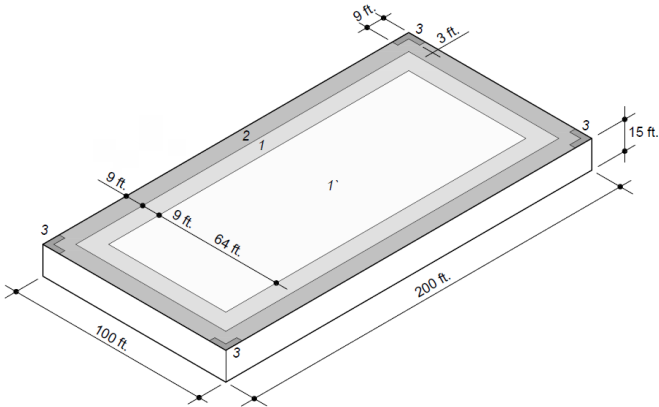

Figure 3: Example of a 100 ft. by 200 ft. roof zone layout for a building 15 ft. high

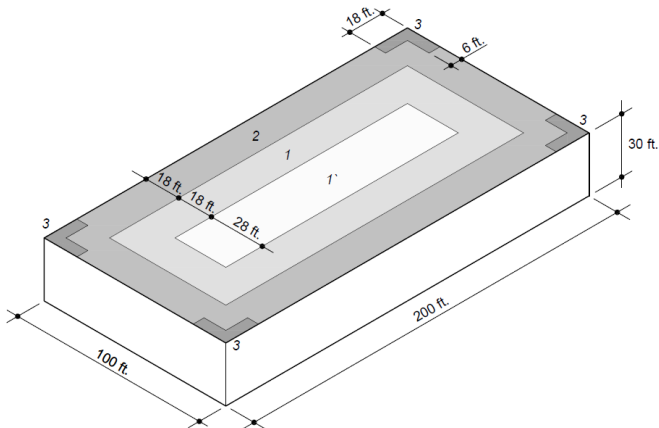

Figure 4: Example of a 100 ft. by 200 ft. roof zone layout for a building 30 ft. high

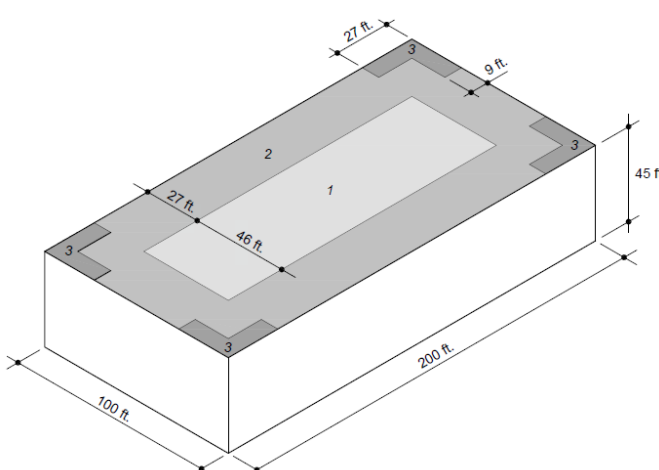
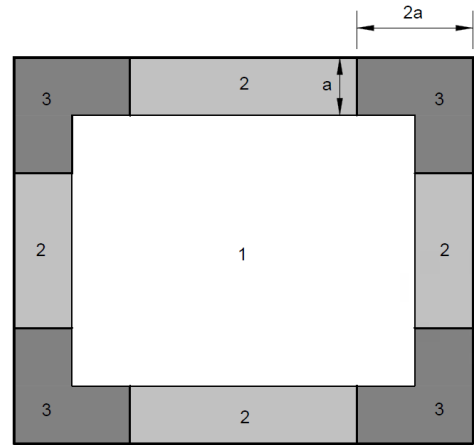

Figure 5: Example of a 100 ft. by 200 ft. roof zone layout for a building 45 ft. high



$a = 10\%$ of least horizontal dimension, but not less than 3 ft.

Figure 7: Roof zone layout for a building greater than 60 ft. high

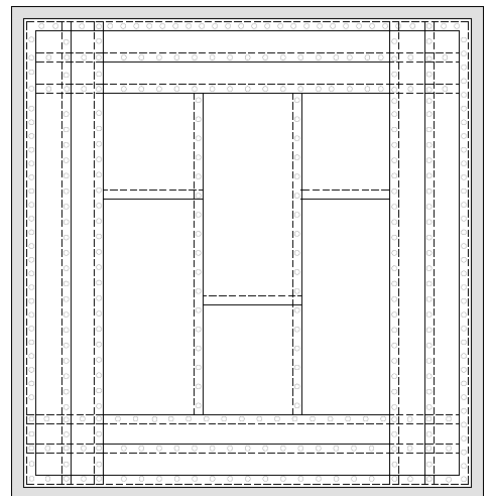

Figure 8: Example of picture framing

Joan Crowe, AIA, is Co-Chair of CRCA's Chicagoland Women in Roofing (CWIR) Committee and a member of CRCA's Industry Affairs / Technical Committee. She is GAF's Director of Codes and Regulatory Compliance and has a B.S. and M. Arch in Architectural Studies and is a licensed architect. She has 30 years of experience in the construction industry. Crowe previously worked at the National Roofing Contractors Association (NRCA) as a Director of Technical Services. For more information, contact joan.crowe@gaf.com.

Roof Talk—Associate



Company: SJ Mallein & Associates

Location: Lombard, IL

Business Founded: 2014

Number of Employees: 8

Joined CRCA: 2014

What Services Does Your Business Offer?

As an independent manufacturer's representative, SJ Mallein & Associates provides a complete building envelope solution based on the diverse lines we represent. This includes everything from commercial roofing to walls, and below grade waterproofing.

We represent leading manufacturers of commercial building envelope systems including Firestone Building Products, Firestone Metal Products, Gaco, GenFlex Roofing Systems, SkyScape Vegetative Roof Systems, SunWave Skylights, Georgia-Pacific DensDeck Roof Board, Westile Pavers, Metal-Era edge and coping systems, Rooftop Anchor safety systems, nVent CADDY Pyramid rooftop mechanical equipment support products, Firestone Enverge wall products, Georgia-Pacific DensElement exterior WRB-AB sheathing, AVM Industries' below grade, blindsided and plaza deck waterproofing, and Kingspan GreenGuard exterior rigid insulation panels.

SJ Mallein represents all the product lines in the greater Chicago area, as well as Westile Pavers in Iowa and AVM and DensElement in Wisconsin.

Where Do You See Your Business in 5-10 Years?

We pride ourselves on exceptional customer service and plan to grow our business as the Chicago market grows. We will continue to structure our product portfolio and align ourselves to provide our customers with products from top tier manufacturers.

What Is Your Best Business Memory to Date?

2014 CRCA Golf outing at Silver Lake. This was our first CRCA event as SJ Mallein and we were proud to announce that we were the new Firestone Manufacturer's Rep's for the Chicago market.

How Did You Learn About CRCA?

Several members of our team have been affiliated with the CRCA for many years prior to the formation of SJ Mallein & Associates. Joining the CRCA as an associate member was one of our first orders of business in 2014.

If You Attend CRCA Events, Can You Describe a Benefit of Attendance?

CRCA events provide our team with the ability to network within the industry.

What Value Does CRCA Membership Bring to You?

The CRCA is a valuable resource to our team, providing us with current industry standards, changes, and trends within the Chicago roofing community. The CRCA provides an avenue to forge and maintain relationships with contractors, engineers, architects, and consultants all within one organization.

What Advice Would You Give a New CRCA Member?

Get involved, join a committee, and take advantage of being at the center of the Chicago roofing community.



SJ Mallein & Associates Photo

Roof Talk—Contractor

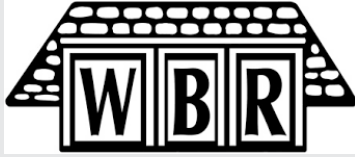

Company: W.B.R. Roofing Company Inc.

Location: Wauconda, IL.

Business Founded: 1998

Number of Employees: 30

Joined CRCA: 2004

What Services Does Your Business Offer?

W.B.R. is a commercial roofing company focusing on new construction, roof replacement, roof recovers, and coatings. Our architectural sheet metal systems include metal wall panels, roof systems, and roof related metal. We offer roof maintenance programs, roof assessments, leak investigations as well as repair work. We install and maintain roofing systems including single ply, modified and BUR systems, metal roof and panel systems, waterproofing, vegetative roof and wall systems.

Where Do You See Your Business in 5-10 Years?

We strive each and every year to be knowledgeable and consultative with our customers. Each and every day our goal is to provide the best service to our customers while continuing to grow relationships.

What Is Your Best Business Memory to Date?

There are many years' worth of memories! But servicing Chicago and its suburbs makes our work worthwhile. WBR has been a staple in the Chicagoland area for over 22 years and we believe family businesses are the cornerstone of America.

How Did You Learn About CRCA?

We were first introduced to the CRCA by other industry professionals in 2004. Knowing their reputation for excellence in the roofing industry, it was a natural transition to becoming a member.

If You Attend CRCA Events, Can You Describe a Benefit of Attendance?

By attending the many industry events, WBR gains invaluable knowledge for our company and for our customers. We love the diverse opportunities the CRCA

provides for its members when choosing events to attend. From monthly committee events, to fundraiser events, to family night at the ballpark, we cannot say enough about the effectiveness of belonging to the CRCA and the ultimate benefits to our company.

What Value Does CRCA Membership Bring to You?

Becoming a member allows opportunities for continuing industry education, mentor programs, legal guidance, and networking opportunities that we would not normally have access. Having CRCA peers and mentors allows us to really become a resource of knowledge and trust for our industry and customers.

What Advice Would You Give a New CRCA Member?

Don't hesitate to attend events! Ask questions, dig deep, and learn from many years of experience from industry professionals. Whether you are a contractor or an associate member, CRCA industry leaders really share their experiences and constantly offer guidance to other members.

Is There Anything Additional That You Would Like to Add That Was Not Asked/Mentioned?

We cannot express enough how the CRCA has positively influenced our company! By becoming members, we've cemented solid relationships with industry leaders and educators and consider ourselves blessed to be a member of this storied organization.



Photos courtesy of WBR Roofing Inc.

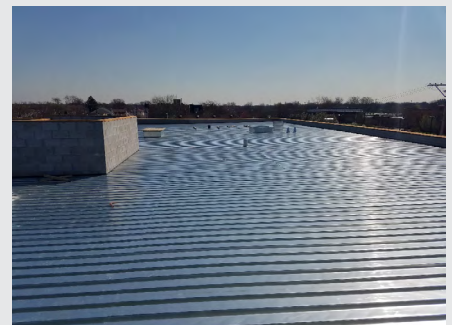

COVID-19 Cyber Security Risks

By Trent Cotney



Trent Cotney

In our current reality, employers have a lot on their plate. From managing staff shortages to complying with new OSHA safety guidelines, cyber security is likely not at the top of most employers' lists of worries. And while that may be understandable, due to the increase in businesses shifting to remote work, cyber-crime

is at an all-time high. It is essential that all employers understand the cyber risks associated with transitioning to remote work and act quickly to put proper procedures in place to both prevent and react to a potential data breach.

While there are several preventative measures that employers should be implementing to combat cyber-crime, analyzing your company's data exposure can go a long way in helping plan for the possibility of an attack. The more employees that you have attempting to access your company's servers from their personal devices—most of which do not contain the security that your office devices likely do—the more opportunity there is for cyber criminals to infiltrate your sensitive corporate data. Experts suggest that requiring your employees to utilize a password protected VPN when using their personal computers for business purposes goes a long way in quelling a possible breach. Adding two-step verification to your VPN will only strengthen the firewall between your company's information and a hacker trying to break through your system. All employees should be made aware of, and be on the lookout for, "phishing emails" from unknown email addresses. Most email platforms give businesses the ability to add banners to internal and external email addresses, allowing employees to identify the source of an email and whether that source is safe to respond to.

However, adding password protection to your company's server is often not enough to prevent cyber-attacks from occurring, and on top of that, it does very little to limit your businesses liability in the event

that a breach does occur. For example, a federal district court in Kentucky recently ruled that victims to a company's data breach can assert claims directly against a company that maintains legally inadequate security measures¹, and rulings like this seem to be the trend amongst courts across the nation. In light of this evolution, it is important for employers to update their employee manuals to include standards for employee use of company devices, access to company documents from personal devices, social media use, handling of sensitive client information, and screen-sharing on video conferences. Equally as important as employers introducing these updates to their employee manuals, is enforcing these policies. Doing so not only helps to reduce your company's exposure to a possible data breach but will also help your company reduce its liability if one occurs.

Your company should also have a detailed security breach response protocol that can be accessed and implemented if and when a security threat arises. In many states including Illinois, businesses that collect or handle private information of consumers must notify those persons, as well as the state Attorney General, immediately upon learning of a data breach. But beyond what is required by your state's statute, companies should introduce crisis management teams that are equipped with the resources to deal with these situations within 24 hours of their occurrence. A company's failure to adequately respond in these times of uncertainty can spell doom for its legal exposure.

As many states are beginning to experience increased numbers of COVID-19 cases, remote working environments are likely here to stay for the foreseeable future. And while one would hope that employers are now better equipped to handle the complications of working from home, only time will tell. Implementing and enforcing standard operating procedures focused on reducing your company's cyber exposure is crucial to the financial security of your business during this time of increased scrutiny and unprecedented challenges. 

Disclaimer: The information contained in this article is for general educational information only. This information

does not constitute legal advice, is not intended to constitute legal advice, nor should it be relied upon as legal advice for your specific factual pattern or situation.

Endnotes

1. McKenzie v. Allconnect, Inc., 369 F. Supp. 3d 810 (E.D. Ky. 2019).

Trent Cotney, CEO of Cotney Construction Law, is a licensed lawyer in the State of Illinois and a member of CRCA. For more information, contact Cotney at (312) 728-2116, tcotney@cotneycl.com or visit www.cotneycl.com.

www.METALDECKSUPPLY.COM
Online Quoting



METAL DECK SUPPLY

50 YEARS 1970 - 2020

Metal Deck Replacement?

- ✓ Largest Inventory in Stock
- ✓ Knowledgeable Staff
- ✓ For Immediate Use
- ✓ Pick Up or Delivery
- ✓ Variety of Deck In Stock
- ✓ Cut to Length

CONTACT US TODAY FOR BEST SERVICE AND LEAD TIME
ALL ORDERS READY IN 2 HOURS FOR TOUCH-FREE PICKUP

VISIT OUR WEBSITE FOR OUR METAL DECK 101
VIDEOS IN ENGLISH & SPANISH

PROUD MEMBER



YOUR ONE-STOP METAL DECK SHOP!
630.978.7800 | sales@metaldecksupply.com



24/7 Availability

General Roof & Emergency Roof Repairs

Reroof, Replacement, New Construction

Roof Inspections and Comprehensive Reports

Custom Preventative Roof Maintenance Programs

**STANDING SEAM, SLATE, SHINGLES, GARDEN/GREEN ROOFING
TPO, EPDM, BUILT-UP, MODIFIED**

COMMERCIAL - INDUSTRIAL - INSTITUTIONAL

1-800-339-8327

Illinois Roofing License # 104-000207

Mobile Crane Safety: Setting up for a Successful Lift

By Brad Runnion

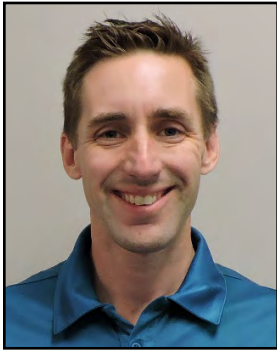

Brad Runnion

When it comes to safely operating a truck-mounted crane, the importance of being knowledgeable about the equipment and carefully planning a job cannot be understated.

Simple mobile crane safety best practices can go a

long way toward avoiding accidents that result from a deficiency in one of the above areas.

For purposes of this article, **we will assume that the machine is properly maintained, serviced, and inspected per the manufacturer, OSHA, and all applicable industry guidelines.**

Mobile Crane Safety Starts with Knowing Your Job

The first step in mobile crane safety, and before operating any piece of lifting equipment, is making sure operators are properly trained and knowledgeable about the equipment. To that end, before you operate any lifting device, you must be properly trained and certified (if applicable) to use the machine you will be working with. Today, there are many companies that provide mobile crane operator training and certification. Aerial work platform and crane work, if not properly performed with the proper planning, procedures and personnel, can be hazardous. Do not attempt to perform any operation with a crane without proper training.



Runnion Photo

Know Your Machine

All machines are different. Make sure you have complete knowledge of the one you will be using. Be familiar with the controls, capacity, and range charts as well as the machine limitations before you attempt to do any work. Thoroughly review, understand, and adhere to the manufacturer's operating instructions provided in the manuals and placards. There is no substitute for knowing how your machine works and using it in the manner by which the manufacturer designed it.

Plan Your Work

You should also have a plan as to how you will accomplish your work. Make sure you have a lift plan as well as a safety plan in place every time you deploy your mobile crane. Ensure that the intended operation is achievable with your equipment. Note obstacles with which you may have to contend. Hazards like energized power lines, road traffic, ground conditions and slopes, among others, are all important to consider when planning a successful lift. Determine whether you are properly staffed for the job, who will be at the site and what each team member's role will be. Make sure you have your site adequately demarcated to ensure it is clear of traffic, bystanders, and passersby. Remember to pay attention to the weather. Different machines are rated differently for various wind conditions. Rain, snow, heat and cold can also impact conditions and machine performance. These must be accounted for to ensure safe operation.

Perform a Walk-Around Mobile Crane Safety Inspection

Once you know how to use your machine and have a plan developed, a thorough walk-around inspection of your machine is essential to ensure the machine is in proper condition before you begin. Follow the manufacturer's and all applicable industry inspection standards. Make sure all components on the machine are in proper working order. This includes hydraulics, electric components and connections, and structural items. If they are not, then they must be fixed before attempting the operation.



Runnion Photo

Get Your Footing

Proper outrigger deployment is critical to the safety of any job. Make sure your outriggers are out the proper distance from the truck and make sure you have adequate ground penetration. Double check the work surface for hazards including underground voids, slopes and soft or loose soil. Use adequate cribbing and outrigger pads to ensure steady and level footing for your machine.



Runnion Photo

Make Sure All Systems Are 'GO'

Today's equipment can have a variety of safety devices and operator aids. If a safety device is not in proper working order, the machine must be taken out of service and operations must not begin until the device is again working properly. If an operator aid is not in proper working order,

the manufacturer's or a qualified person's recommendation for continued operation or shutdown shall be followed.

Do the Work Before the Work

Setting up for the rest of your operation may include deploying a jib, attaching a work platform, reeving a load line and hook block, and any number of other tasks, depending on the machine and how you plan to use it. Ensure you properly secure any attachments or auxiliary devices per the manufacturer's guidelines.

Do the Lift Before the Lift

Mobile crane safety best practices mandate that all people involved in the planned work follow all rules set forth by OSHA and all applicable industry standards. When lifting personnel with a certified ASME B30.5 Mobile and Locomotive Crane, a trial lift and proof test are required as set forth by OSHA 1926.1431.

Mobile Crane Safety Requires Physical and Mental Fitness

Crane work can be challenging—physically and mentally. Being physically fit, stretched, and flexible and mentally alert will make your work go smoother. Proper diet, sleep and exercise will all contribute to your safety on the job. Be sure you are trained on other aspects of this work including lifting techniques.

Dress for Success

Make sure you have and are utilizing all required safety equipment. Proper protection from head to toe is essential for mobile crane safety. Make sure you are using up-to-date and properly functioning safety equipment. A broken hard hat, torn safety lanyard or other non-compliant devices do not constitute adequate protection.

A Team Is a Powerful Thing

Like a pit stop in a NASCAR race, teamwork and communication can be the difference in crossing the finish line. Know your crew, know your hand signals, and know how to communicate properly within your team. If the team pays attention, communicates, and works together, the results of the work will reflect that commitment.

Whether you are lifting materials, proper training, planning, preparation, and execution will increase mobile crane safety, making your work more efficient and more enjoyable. 

Brad Runnion is the Sales Manager for CRCA Member Firm Runnion Equipment Company which specializes in sales and service of National Crane Boom-Trucks and Palfinger knucklebooms. Runnion Equipment also sells Elliott and Dur-A-Lift man lifts and bucket trucks and services all types and manufacturers of cranes. For more information, call 708-447-3169 or visit <http://www.runnionequipment.com>.

Industry News

By CRCA Staff

CRCA Jumps Webinar Participation with COVID-19

CRCA is well known for industry networking events that draw members together on a wide range of industry and business topics on an annual basis. However, when the pandemic hit in March, CRCA's leadership opted to deliver important, timely industry and business education through virtual means.

Since early April, CRCA has hosted eleven member and industry webinars presented by roofing, waterproofing and construction experts, to provide this needed information through "Thursdays With CRCA". Topics included: Air Barrier Basics, COVID-19 updates, Energy Code for Re-Roofing Low Slope as well as Residential, Key Contract Provisions, Anti-Sexual Harassment, Multiple Employer Investment Plans and more.

CRCA thanks the following industry partners for their participation. Watch CRCA.org for upcoming webinars that provide value to your firms and municipalities and provide important information during these difficult times. If you are interested in providing industry specific, product generic education to roofing and waterproofing professionals, contact info@crca.org.

- Assured Partners Inc. / Esser Hayes Insurance Group
- Cotney Construction Law, LLP
- Hendrick Phillips Salzman & Siegel, PC
- Laner Muchin
- Merrill Lynch / J&R Group
- Safety Check Inc.
- Smith Amundsen

CRCA Foundation Gains a New Member!

In early July, Bennett & Brosseau Roofing, Inc. became the seventh member of the CRCA Foundation with their Bronze Level Contribution, joining Cotney Construction Law, LLP, GE Riddiford Company, Elens & Maichin Roofing & Sheet Metal, Inc., Knickerbocker Roofing & Paving, MW Powell, Sterling Commercial Roofing as well as Friends of the CRCA Foundation: Pine Roofing Company and Roofs, Inc.



The Foundation, organized in late 2017, has a mission to:

- Identify and Support Philanthropic and Humanitarian Relief
- Invest in the Future of Roofing and Waterproofing Products, Materials and Equipment through Research
- Provide Financial Support to open educational doors for students and others, removing the obstacles to success

As we move forward, stakeholders' support is needed to help secure the future and strengthen the roofing industry and community surrounding it. How can you help? Contact crcafoundation@crca.org or call 708-449-330 today.

The CRCA Foundation Awards Scholarships:

Since the 1990s, both the CRCA and the Chicagoland Roofing Council have awarded over \$715,000 in new and renewable scholarships to deserving students, to help with the increasing large financial burden of collegiate education. Many past recipients have graduated and headed into such fields as medicine, research, engineering, business and more. Starting in 2019, the CRCA Foundation began to award these funds.

The CRCA Foundation would like to recognize the following 2020 Scholarship Recipients and wish them luck as they prepare to head off to college this fall. We would also like to recognize Brenda Huerta (Anthony Roofing, a Tecta America Company), who while received the CRC / CRCA Foundation Award this year, has opted to join the Illinois National Guard and serve our state and country instead.

CRCA / CRCA FOUNDATION



Trishia Cueto
Williams College



Megan Howley
Univ. of Notre Dame

CRCA / CRCA FOUNDATION



Julissa Acosta
Prairie State College
Anderson &
Shah Roofing



Abby Baetzel
Southern IL Univ.
Sullivan Roofing



Heather Blankenship
Aurora Univ.
Combined Roofing



Joseph Brueck
Univ. of Missouri
Olsson Roofing



Madison Bylak
Illinois State
IWS



Eduardo Jara
Denison Univ.
Olsson Roofing



Bridget Jeffries
Univ. of St. Francis
Waukegan Roofing



Joanna Lopez
Harper College
A-1 Roofing



Magaly Muro
DePaul Univ.
Chicago Park Distr.

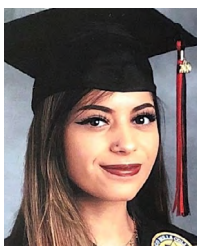

Evelyn Perez
Univ. of IL
Bennett &
Brosseau Roofing



Vena Prudent
Missouri S&T
Vac-It-All

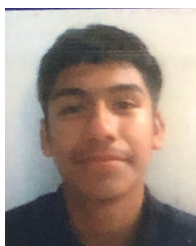

Anthony Ruiz
To Be Determined
Bennett &
Brosseau Roofing

CRCA / CRCA FOUNDATION CONTINUED

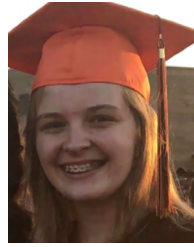

Kayla Strezo
Univ. of Iowa
MW Powell Company

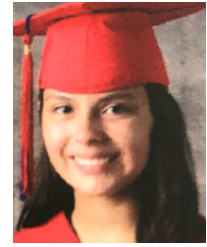

Alexandria Trujillo
Aurora Univ.
Olsson Roofing

Raindrop Gutter Guard Acquired by Klaus Roofing Systems

CRCA Member firm's owner Steve Nitch announced on July 1, 2020 that Raindrop Gutter Guard has been acquired by Klaus Roofing Systems, a Division of Contractor Nation. Contractor Nation is based in Seymour, CT and was founded in 1987. The company has eight dealer contractor networks, a materials distribution operation, an internet marketing agency for contractors, and a finance company. The division that will be handling Raindrop is called Klaus Roofing Systems.

Nitch, Raindrop's inventor, stated, "We are excited to announce that after many years of development of the best gutter guard available anywhere, Raindrop Gutter Guard has been acquired by Klaus Roofing Systems."

He went on to thank all the Raindrop customers for their support over the years and feels that "... the team at Klaus Roofing/Contractor Nation was a great choice to continue with this great product." For more information, contact Mike Rubin at Klaus Roofing Systems at 800-541-0487 or email mrubin@contractornation.com.

Runnion Adds to Sales Staff and Expands with Knapheide



Runnion Photo

CRCA Member Runnion Equipment announced June 30th that John Pielli has joined the sales team. Pielli has over 30 years of crane experience both as a mechanic and salesman, worked previously at Hiab and will have a Northern Illinois focus.

Runnion Sales Manager Brad Runnion stated, "We are incredibly excited to have John on board and working for Runnion Equipment Company. With twenty-one years as a mechanic and over seven years in sales, John has an intimate knowledge of lifting equipment which allows him to provide a unique perspective that will help deliver creative solutions and real value to our customers."

Runnion also announced the expansion of Knapheide body offerings. They have been utilizing Knapheide bodies for their National Crane boom trucks and Palfinger knucklebooms for many years. Now, with their recent expansion, they have the room and capability to expand into the sales and upfitting of service/utility bodies and dump bodies—as supplied by Knapheide.

Michael Prochot, President of Runnion Equipment, states “This is an exciting opportunity for us. Knapheide is a first-class family owned company with an outstanding product line. Our intent when building our new facility was to give us space to stretch by utilizing the skills we have honed over the years in servicing and mounting truck mounted cranes as a steppingstone to other upfitting markets. We are very pleased that Knapheide is giving us this opportunity to represent them as a full line dealer.”

Carlisle Syntec Announced New Rep Partnership

On March 3, 2020, Carlisle Syntec Systems announced a new partnership with AAdvanced Building Products, an independent sales rep agency, which has expanded their sales territory to include the Chicagoland area. AAdvanced of Chicago has opened a new office in Oak Brook, IL. They also represent Carlisle SynTec Systems

in Indiana, Ohio, and Kentucky, with current offices in Carmel, IN, Beachwood, OH and Louisville, KY.

AAdvanced brings 23 years of experience as a manufacturer’s representative of single ply products and include representatives Tom Averitt, Jeff Smith, and Jason Clayton. Frank Arevalo, formerly of USG Securock, has also joined the team.

Carlisle and AAdvanced will continue to work hand-in-hand with their current Distribution Partners: Bone Roofing Supply Inc., ABC Supply Co. Inc., and Lakefront Supply. For more information, contact jrclayton@aadvanced.com or <http://www.aadvanced.com/>.

OMG EdgeSystems Rebrands It Popular Line of PermaSnap Coping

OMG Roofing Products announced on June 30, 2020, that its popular line of PermaSnap Coping, EdgeSystems has been re-branded to include the former QuickSnap Coping Products. EdgeSystems traces its roots to the industry’s first pre-engineered edge metal system 75 years ago.

The re-named and expanded product line includes four products that provide contractors with more choices for every type of commercial application:



APOC 581 ARMOR FLASH®

DESCRIPTION: APOC® Armor Flash® 100% Silicone Patch & Sealant is a high performance repair product for use in roofing & waterproofing applications in conjunction with silicone coatings. Not recommended for use with acrylic, aluminum or asphalt coatings. Armor Flash is highly flexible and can be used to seal flashings, curbs, penetrations, seams, HVAC Units and many other types of repairs.

- Fast & Easy to Use
- Single Component
- Versatile Application
- Solvent Free Polymers



SILICONE SERIES | ENERGY EFFICIENCY | ROOFING

www.apoc.com
Contact Elizabeth Seko at (224) 806-3195

- PermaSnap—formerly QuickSnap—for walls from 6–24-inches wide.
- PermaSnap Plus—formerly QuickSnap Plus—for walls from 6–32-inches wide.
- PermaSnap Premier—formerly PermaSnap—for walls from 4–24-inches wide.
- PermaSnap Premier Plus—formerly PermaSnap Plus—for walls from 4–32-inches wide.

PermaSnap and PermaSnap Plus are ES-1 tested only for non-Factory Mutual projects. PermaSnap Premier and PermaSnap Premier Plus are both ES-1 tested and approved for use by Factory Mutual. For additional information, contact OMG EdgeSystems customer service at 800.892.9173, visit OMGEdgeSystems.com, or contact your local OMG field sales representative.

Petersen Adds Canadian Technical Representatives

CRCA Member Petersen Aluminum announced on June 30 of an expansion of its network of manufacturer representatives into Canada to meet the country's growing demand for metal roof and wall cladding systems.

The manufacturer representatives from Enercorp will support Petersen's PAC-CLAD architectural metal cladding products to architects, consultants, installing contractors and others involved in the specification and installation of exterior metal cladding products from coast-to-coast across Canada.

Enercorp is the professional sales and marketing firm for Division 7 systems (Thermal and Moisture Protection) and Division 9 (Finishes) products and systems, with offices across Canada. The firm also represents products made by Carlisle Construction Materials, which owns Petersen. PAC-CLAD products will be shipped from its Elk Grove Village, IL facility.

"Partnering with Enercorp to represent Petersen is a significant step toward successfully servicing Canadian design and construction professionals who are looking for metal roof and wall products. The sales team at Enercorp will satisfy the architectural metal needs of Petersen's existing and new customers in Canada as we grow the PAC-CLAD brand," said Mike Petersen, president.

Contact Enercorp's Dan Meskell at danielm@enercorp.ca for information about PAC-CLAD representatives in Canada or visit pac-clad.com to learn more about the complete line of metal products.

CRCA and the Roofing Industry Loses Great Friend



Dr. Rene M. Dupuis, Structural Research Inc., passed away, age 77, on Saturday, May 23, 2020 from heart failure. The roofing industry has lost a great friend.

Along with close friends from the University of Wisconsin Engineering Program, Dupuis founded SRI in 1978. He quickly became known for his problem-solving skills and was renowned as a designer and researcher worldwide.

Dupuis developed a love and commitment to the roofing industry, providing research, education, and expertise to both the seasoned roofing professional and to those just starting out. A frequent CRCA and industry presenter, he collaborated on technical education, code and also provided over 100 published works.

The University of Wisconsin recognized his many contributions to the construction industry by establishing the Rene M. Dupuis Scholarship in Civil Engineering. For more information, contact www.supportuw.org/giveto/dupuis scholarship.

CRCA Legislative News from Margaret Vaughn



CRCA Photo

General Assembly Returns To Wrap Up Spring Session

The Illinois General Assembly returned to Springfield on May 20th for the first time since March 5th for a four day "Special Session". The Capitol Complex had been closed since the *Shelter in Place Order* was first put into place. In order to allow more room for social distancing, the House met at the Springfield Convention Center and the Senate did most of business from their individual offices in the Capitol. Only ten senators at a time were allowed on the Senate floor to vote. It was a "Special Session" with a limited agenda related to legislation focused COVID-19 response, state budget, hospital assessment program (which was critical because he depends on \$3.5 billion in Medicaid funding from feds), laws sunseting before June 2021, General Election, and Constitutional Amendments. The rest of the substantive legislation from earlier in the session will not be addressed until the fall veto session or the spring session 2021 which begins in January.

Workers Compensation & COVID-19

The Workers Compensation Commission (WCC) filed Emergency Rules on April 15th Rule that basically stated if **any** "essential" worker (not just healthcare or first responders) came down with COVID-19, it would automatically be assumed that it was contracted at work and the employer would be liable under rebuttable presumption unless they could prove otherwise, which would be very difficult to do. CRCA launched a lobbying campaign with the legislators who serve on JCAR (Joint Committee on Administrative Rules) who were scheduled to vote to make the Emergency Rules permanent. The following week, CRCA joined other businesses groups in a lawsuit filed against the State by the Illinois Manufacturers Association and the Illinois Retail Merchants Association. This resulted in the WCC withdrawing the Rules on April 27th on the grounds that the WCC did not have the legal authority to adopt such far reaching rules.

As part of their special session agenda, the legislature passed HB 2455 which address how COVID-19 would be handled in Workers Comp cases for essential workers and became a public act on June 5, 2020. Under this act:

1. Essential employees who are not required by their employer to encounter members of the general public OR are in work environments with 15 people are less exempt from the new law.
2. If an essential worker goes before the Workers Comp Commission, with an injury or occupational disease resulting from COVID-19, it shall be rebuttable presumed to have arisen out and in the course of their employment. **However**, as a defense, the employer can use ordinary presumption to rebut the claim with evidence that CDC or IDPH guidelines were followed. As long as "some" evidence of this type is submitted, the "presumption" ceases and the case is determined on evidence as if the presumption did not exist.
3. The employee has to have actually contracted COVID-19 (*not just been exposed*)
4. The employer's experience modification will not change due to any COVID case.
5. The provisions in the legislation apply to COVID-19 cases contracted between from March 9th to December 31st, 2020.

CRCA strongly encourages all construction professionals to have controls in place to protect employees from contracting COVID-19 and also companies against COVID-19 related claims. Be sure your company manual is up to date to include COVID-19 policies!

IL State Roofing Advisory Board

The Illinois State Roofing Advisory Board is a grievance board under the Illinois Department of Financial and Professional Regulation that reviews cases brought to them for disciplinary action after IDFPD has completed their investigation. CRCA worked to get the Advisory Board added to the Roofing Industry Licensing Act back in the mid-1990s and since that time many members of CRCA have been appointed. The Board consists of 7 licensed roofing contractors and one knowledgeable public member. Rod Petrick (Ridgeworth Roofing) is the current Chairman and Tony Roque (M.W. Powell Company) was just appointed in March as the newest contractor member. Travis Gorman (Roofers Local 11) was appointed as the public member. Several other CRCA members are in the appointment process.

IDOL Announces Hiring Requirement

The Illinois Department of Labor (IDOL) announced a new state law that requires that the workforce on all

ADVANCED ARCHITECTURAL
SHEET METAL & SUPPLY

We service your needs with consistent quality, workmanship and knowledge

It's part of the reason customers come back to us time after time.

Maximize your profits by decreasing your inventory.
Reduce man hours - let us fabricate, you install.

98% of our American-made products are made-to-order and are manufactured inhouse. Our products are made from domestic metal and custom crafted to your specifications.

Contact us today to see how we can streamline your process and maximize your profits!

(231) 861-0050 | info@advarchsm.com | www.advarchsm.com

public work projects to be comprised of 90% Illinois residents. Effective July 1, 2020, the new requirement, called the Illinois Workers on Public Works Act, was enacted due to the record high Illinois unemployment during the COVID-19 pandemic.

Illinois Attorney General Kwame Raoul pledged to work with the IDOL to enforce the law. Raoul stated, "As the nation faces record levels of unemployment, the people of Illinois should be assured that government is using all available tools to put Illinois residents back to work." The law is intended to ensure that projects funded using public dollars employ Illinois residents. For more information, visit: <http://www.ilga.gov/legislation/ilcs/ilcs3.asp?ACTID=549&ChapterID=7>.

ASCE7-16: New Code Alert

The 2018 International Building Code (IBC) has been or is being adopted by several jurisdictions in the State of Illinois. The 2019 Chicago Building Code (CBC), recently published, will be in effect for buildings permitted as of August 1, 2020.

Both the 2018 IBC and 2019 CBC require wind uplift loads for the roof assembly to be calculated in accordance with new American Society of Civil Engineers Standard ASCE 7-16—before selecting a roof system. The new ASCE7-16 has much more stringent wind uplift

requirements meaning that insulation fastening increases dramatically—and with it, labor, and material costs.

Each municipality adopts codes individually, so requirements will vary from jurisdiction to jurisdiction—depending on which code has been adopted, ex., 2012, 2015, 2018 IBC. CRCA Members can visit the CRCA Members' Only Portal, (under 'Code Information'), to find information for the respective municipality.

Be sure to verify which code the roof was permitted under as there is a lot to know about the new requirements in the 2018 IBC and 2019 CBC. If the code is 2018 IBC or later version, or if the building is in the City of Chicago and permitted after Aug. 1, 2020—it means that ASCE 7-16 determines the design wind loads used to select a roof system. The wind uplift resistance is determined by testing and design parameters including building height, and more. Consult with each individual manufacturer for the fastening pattern required based on their individual test results for compliance.

Check out the article in this issue of *CRCA Today* by Joan Crowe on this new development. Watch future issues of *CRCA Today* for articles on ASCE 7-16. Check out the archives too, to build understanding of the new code requirements.



METAL DECK PRODUCTS AND ACCESSORIES



Wrigley Field | Chicago, IL



QUALITY DECK PRODUCTS:

- Roof Deck
- Floor Deck
- Composite Deck
- Form Deck
- Cellular Deck
- Acoustical Deck
- Accessories

Cordeck manufactures and delivers the widest range of quality corrugated steel deck products and accessories for virtually any building application or requirement.



Connect With A Cordeck **Dexpert**® Today!

877.857.6400 | sales@cordeck.com | cordeck.com

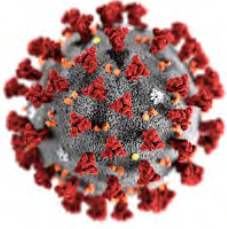

COVID-19 UPDATES

CARES ACT Authorizes Tax Credit

Don't miss checking to see if your company qualifies for one of the key components of the new **Coronavirus Aid, Relief, and Economic Security (CARES) Act**. The new law authorizes a tax credit—a dollar-for-dollar reduction of your tax bill—to eligible employers that retain workers during the COVID-19 outbreak.

Background: The employee retention credit equals 50% of the qualified wages an employer pays to employees after March 12, 2020 and before January 1, 2021. Eligible employers can benefit immediately by reducing payroll tax deposits that are otherwise due. Also, if an employer's current payroll tax deposits are not sufficient to cover the credit, it can obtain an advance payment from the IRS.

Only the first \$10,000 of wages paid to an employee during the designated time frame qualifies for the credit. As a result, the maximum credit is limited to \$5,000 per employee—still a significant amount.

A business is eligible to claim the employee retention credit if either of these requirements are met during any calendar quarter:

- It fully or partially suspends operations during any calendar quarter because of government orders limiting commerce, travel, or group meetings due to the COVID-19 outbreak; or
- It experiences a significant decline in gross receipts. For this purpose, a "significant decline" occurs when gross receipts are less than 50% of the gross receipts for the same calendar quarter in 2019.

The credit applies to qualified wages (including certain health plan expenses) paid during this period or any calendar quarter in which operations are suspended. The definition of qualified wages depends on how many employees worked for the employer last year.

Note that an employer is not eligible for the employee retention credit if it receives a loan under the **Paycheck Protection Program (PPP)** created by the CARES Act. Similarly, a business cannot claim the credit for the



One Call Gets It All...
 For All of your Roofing Equipment Needs
 Local 708-656-7700
 Toll Free 1-800-922-5508
 Fast, Friendly, Knowledgeable
 Service Backed By Years Of Experience

WALTER PAYTON POWERING YOUR JOBSITES



Walter Payton Power Equipment • 930 W. 138th Riverdale, IL 60827

www.wppecrane.com

email: info@wppecrane.com

Crane Certifications • PM Services • Equipment Rebuilds • Painting & Restoration

OEM Parts • Onsite Field Service • Shop Service • Third Party Inspections

same wages designated as the paid sick and family leave available under the Families First Coronavirus Response Act or the family and medical leave credit authorized by the Tax Cuts and Jobs Act (TCJA). For clarification, contact your tax professional.

Significant Changes to Forgiveness of PPP Loans Under the Cares Act

CRCA Member Hendrick, Phillips, Salzman & Siegel forwarded key information in June regarding the Senate’s update to the provisions of the CARES Act calling for forgiveness of Paycheck Protection Program (“PPP”) loans.

Under the original provisions, borrowers receiving PPP loans could apply to have the loan forgiven (in whole or in part) to the extent the borrower was able to use the proceeds of the loan for payroll costs, interest on secured loans, rent, and utilities over the course of the 8 weeks after the loan was funded. SBA guidance added the requirement that non-payroll costs would be limited to 25% of the total spent for purposes of calculating the amount of the loan to be forgiven (meaning that payroll costs had to total at least 75% of the amount spent). In addition, employers who had been forced to lay off workers were allowed to restore their workforce by June 30 to meet the program’s standards for maintaining workforce and payroll and still receive loan forgiveness.

The latest bill changes these requirements. Employers will now have 24 weeks (or until the end of the year, whichever comes first) to use the proceeds of a PPP loan for payroll and the other allowable costs for the purposes of calculating the forgiveness amount. The deadline for

restoring workforce is also extended to 24 weeks after the loan is received. And the portion that must be spent on payroll costs has been lowered from 75% to 60%, although it appears that if at least 60% is not spent on payroll costs, the loan will not be subject to forgiveness at all.

For further information, contact Scott Calhoun at Hendricks, Phillips at sdh@hpslaw.com.

Other Industry News

CSI Chicago Announces 2020/2021 Board of Directors



CSI Photo - Brad Schwab



CSI Photo - Paul Fogarty

CSI Chicago announced its new 2020/2021 Board of Directors in June for their upcoming fiscal year (July 2020–June 2021). Congratulations to CRCA members Brad Schwab (Schwab Group) and Paul Fogarty (SJ Mallein & Associates) on their new CSI Chicago Board roles. Schwab will be serving as this year’s CSI Chicago President and Fogarty will be serving as the CSI Chicago Secretary. We look forward to our continued partnership with CSI Chicago.

To view the comprehensive list 2020/2021 Board of Directors visit www.csichicago.org.

CRCA Supports NRCA in Residential & Commercial Tax Credit Proposal

CRCA joined the National Roofing Contractors Association (NRCA) in mid-July in support of a new proposal from Standard Industries to provide a 30% federal tax credit for the cost of improvements made to residential and commercial buildings. Specifically, the proposal would provide for a new refundable 30% “Home Improvement Credit” for qualified home improvements for taxpayers up to a certain income level. For commercial buildings, the proposal also would provide a taxpayer with a refundable tax credit equal to 30% of the cost of “qualified

M.W. POWELL COMPANY

SINCE 1847



CRCA Member - NRCA Member - MRCA Member - HACIA Member - MBE Certified

All types of low slope roofing

High-Rise work

Vegetative Roof Systems

Architectural Sheet Metal

IL LIC # 104.000206

P: 773-247-7438
 F: 773-247-7441
 3445 S. Lawndale Ave.
 Chicago, IL 60623

investment property" which would include nonresidential roof improvements.

CRCA believes this proposal could be particularly beneficial to the roofing and construction industries to the extent that the COVID-19 pandemic continues to put pressure on homeowners and commercial building owners to delay and cancel construction projects in the medium and long-term. As such, CRCA joined NRCA & other national roofing industry associations in sending letters to key members of Congress and President Trump in support of this proposal.

Chicago Building Commissioner Retirement Announcement



City of Chicago Photo

The City of Chicago announced in mid-June that Building Commissioner Judy Frydland will be retiring. Frydland worked for the City of Chicago for 31 years and led the city's Department of Buildings since 2015.

As chief of the Department of Buildings, she oversaw 295 employees responsible for

the permitting, inspection, and enforcement of the city's building code. She was responsible for permit process reforms as well as a full rewrite of the city's Building Code in 2019, the first in 70 years. She worked closely with CRCA's leadership during the building code re-write on roofing specific language and even presented to the membership in 2019.

In a statement, Mayor Lori Lightfoot thanked Frydland for her three decades of service to Chicago. She stated, "In her role as head of the Department of Buildings alone, she leaves behind a legacy of strengthening City operations through modernizing our building codes, working with communities to maintain housing stock, and streamlining our permitting process," Lightfoot said. "I join her many friends and colleagues in congratulating Commissioner Frydland on her well-earned retirement and give her my best wishes as she and her family embark on this new chapter of their lives."

Frydland stated that she is retiring to spend more time with her family, including her almost 91-year-old mother, a Holocaust survivor. 

COME, JOIN US



SCHOLARSHIP - RESEARCH - ADVOCACY

WHAT ARE YOU WAITING FOR?



Become a part of the CRCA Foundation and support philanthropic causes, research and education to further the roofing and waterproofing industry and community.

Visit www.crca.org/crcafoundation to learn more or contact the CRCA office at 708.449.3340

The CRCA Foundation is registered with the Secretary of State of Illinois as a charitable, not-for-profit corporation (No. 7122-868-1) and with the US Internal Revenue Service as a 501(c)(3) tax-exempt organization, Federal Tax ID# 82-2888590.

CRCA Contractor Members

The Contractor Members of the Chicago Roofing Contractor Association install all types of roofs, including reflective single ply, modified bitumen, built up, gravel, reflective coatings, shingle, shake, slate and tile, vegetative garden or photovoltaic coverings. From formation following the Great Chicago Fire of 1871, CRCA Members have moved with the times and technology, yet continue to maintain some of the same goals set forth over 140 years ago. To find a CRCA Professional Contractor, visit www.CRCA.org.

- A+ Roofing Co., Inc.**.....(630) 227-1111
- A-1 Roofing Co.**.....(847) 952-3600
- Active Roofing Co., Inc.**.....(773) 238-0338
- Adams Roofing Professionals, Inc.**.....(847) 364-7663
- Adler Roofing and Sheet Metal, Inc.**.....(815) 773-1200
- Advanced Roofing & Woodworking Inc.**.....(630) 231-7663
- Aegis Construction Group, Inc.**.....(630) 709-8121
- Air Pressure Damp Proofing**.....(847) 394-4100
- All American Exterior Solutions**.....(847) 438-4131
- All Sealants, Inc.**.....(708) 720-0777
- Allendorfer Roofing Co., Ltd.**.....(773) 463-7808
- Allied Waterproofing, Inc.**.....(630) 654-9700
- Anderson & Shah Roofing Inc.**.....(815) 741-0909
- Anthony Roofing Tecta America LLC**.....(630) 898-4444
- Apex Exteriors, Inc.**.....(847) 531-8960
- Bennett & Brousseau Roofing, Inc.**.....(630) 759-0009
- R. E. Burke Roofing Co., Inc.**.....(847) 675-5010
- C.P.R. Roofing, Inc.**.....(815) 399-6989
- Care Sheet Metal & Roofing, Inc.**.....(708) 387-9784
- Champion Roofing, Inc.**.....(847) 673-7663
- Clark Roofing Co.**.....(708) 681-2200
- Coleman Roofing, Inc.**.....(708) 755-6800
- Combined Roofing Services LLC**.....(630) 231-4422
- Complete Building Maintenance Co.**.....(630) 932-7890
- Connelly Roofing, Inc.**.....(630) 941-8598
- Countryside Roofing, Siding & Windows, Inc.**.....(847) 221-5600
- Crawford Roofing Experts, LLC**.....(708) 385-5555
- Crowthier Roofing & Sheet Metal & HVAC**.....(815) 726-2400
- CSR Roofing Contractors, Inc.**.....(708) 848-9119
- Custom Roofing Contracting LTD**.....(847) 639-8400
- DCG Roofing Solutions Inc.**.....(847) 296-6611
- Deluxe Roofing Inc.**.....(847) 404-9775
- Distinctive Roofing, Inc.**.....(815) 986-0831
- Domain Corporation**.....(773) 628-0001
- Dream Restorations Inc.**.....(630) 202-2236
- Dunne Roofing Company**.....(847) 696-1643
- DuSable Construction Co.**.....(773) 463-9290
- E. Ariel Roofing Solutions LLC**.....(224) 357-8745
- Economy Roofing**.....(773) 521-2000

- Elens & Maichin Roofing & Sheet Metal, Inc.**.....(815) 727-2689
- Elite Home Restoration, Inc.**.....(630) 823-8580
- F & G Roofing Company, LLC**.....(708) 597-5338
- Feze Roofing, Inc.**.....(630) 530-5944

- Filotto Construction**.....(815) 740-5461
- First Home Improvement Inc**.....(847) 496-5530
- Foremost Improvements Inc.**.....(847) 376-8617
- Freeport Industrial Roofing**.....(815) 235-5350



Lifting Equipment for the Roofing Industry



New and Used Equipment for sale and rent
Rental Cranes available by the day, week, month, or longer
Knowledgeable Technicians factory trained to do the job right
Large Parts Inventory ready for delivery

NATIONAL CRANE
by Genie



Call us or visit our new, state of the art facility!
800-824-6704 • 6201 East Avenue, Hodgkins, IL 60525
www.runnionequipment.com

CRCA Contractor Members

Galewood Tuckpointing & Roofing Co., Inc......(708) 452-7900
GC Roofing LLC.....(773) 766-3421
Gold Standard Restorations Inc......(847) 559-0776
H.C. Anderson Roofing Company, Inc......(815) 624-4129
Henson Robinson Company.....(217) 944-8451
Huebner Roofing Inc......(630) 257-9394
Industry Elite Services, LLC.....(630) 436-6859
Inside-Out Roofing.....(630) 406-3000
J. P. Larsen, Inc......(708) 293-7662
Jones & Cleary Roofing / Sheet Metal Co., Inc......(773) 288-6464 x23
Joneson Roofing and Home Repair.....(773) 474-4963
Kerry Roofing & Masonry.....(708) 422-3004
Knickerbocker Roofing & Paving Co., Inc......(708) 339-7260
Knorr & Myers Roofing Co......(815) 654-1878
Korellis Roofing, Inc......(219) 844-1400
Kreiling Roofing.....(309) 673-3649
Kremer & Davis, Inc......(763) 788-5835
L. Marshall Roofing & Sheet Metal, Inc......(847) 724-5400
Langlois Roofing, Inc......(815) 933-8040
LEAK STOP Roofing, Inc......(847) 719-2775
Licitra Roofing Inc......(708) 485-4848
Lindholm Roofing.....(773) 283-7675
Local Roofing Co., Inc......(847) 244-0500
M&T Exteriors Inc......(331) 240-2911
M. Cannon Roofing Company, LLC.....(847) 519-0698
M. W. Powell Company.....(773) 247-7438
Malcor Roofing of Illinois, Inc......(630) 896-6479
Matthews Roofing Company, Inc......(773) 276-4100
McDermaid Roofing & Insulating Company.....(815) 963-8458
Metalmaster Roofmaster.....(815) 459-6415
MidAmerica Roofing, Inc......(630) 759-7500
Mortenson Roofing Co., Inc......(815) 464-7300
NIR Roof Care, Inc......(800) 221-ROOF
Nombach Roofing & Tuckpointing.....(708) 388-1090
Norton Sons' Roofing Company, Inc......(630) 257-8180
Olsson Roofing Company, Inc......(630) 892-0449
O'Neill Contractors, Inc......(773) 774-2029
P & B Rebuilders.....(708) 456-1099
Peterson Roofing, Inc......(847) 590-5290
Pine Roofing Company.....(773) 539-9595
Pine Waterproofing & Sealants.....(847) 678-5700
Prate Roofing & Installations LLC.....(847) 526-6402
Premier Construction, Inc......(630) 590-9305
Preservation Services, Inc......(815) 407-1950

Proliance General Contractors, Inc......(630) 541-3923
Pro-Tech Roofing, Inc......(847) 759-1970
Protop Roofing.....(847) 559-9119
Prusak Construction & Roofing, Inc......(708) 422-2624
R. B. Crowther Company.....(815) 942-6623
Raincoat Roofing Systems, Inc......(708) 681-5757
Rako Roofing Inc......(773) 780-5482
Reliable Roofing.....(888) 279-7663
Renaissance Roofing, Inc......(815) 547-1725
G. E. Riddiford Company.....(847) 437-5771
Ridgeworth Roofing Co., Inc......(708) 598-0039
Roofing Systems, Inc......(815) 654-9540
Roofs, Inc......(708) 447-9300
Sager Sealant Corporation.....(708) 354-9300
Seal Tight Exteriors, Inc......(708) 755-3555
Showalter Roofing Service Inc......(630) 499-7700
SMART Roofing, Inc......(773) 992-5100
Solaris Roofing Solutions, Inc......(630) 639-5400
SRS Exteriors.....(708) 330-7050
Sta-Dry Roofing.....(770) 849-0079
STAR Roofing & Siding Co. Inc......(773) 588-6550
Sterling Commercial Roofing, Inc......(815) 626-7744
Stewart Roofing Company.....(773) 264-1754
Style Exteriors Inc......(847) 865-3069
Sullivan Roofing Inc......(847) 908-1000
Tecta America Illinois Roofing.....(630) 554-2200
Tidwell Roofing & Sheet Metal.....(847) 437-2710

Tolberts Roofing & Construction Services, Inc......(708) 389-7779
Tori Construction, LLC.....(708) 389-1530
Total Roofing & Construction.....(708) 201-7550
Total Systems Roofing Inc......(815) 455-7663
Trela Roofing & Remodeling.....(708) 422-7204
Union Roofing Co., Inc......(815) 945-2141
Van Doorn Roofing Inc......(847) 228-5800
W.B.R. Roofing Company, Inc......(847) 487-8787
Waukegan Roofing Company, Inc......(847) 623-1625
Weatherguard Roofing Company.....(847) 888-3008
Windward Roofing & Construction Inc......(773) 638-6580
WW Construction & Roofing, Inc......(708) 250-3319
Zera Construction, Inc......(847) 966-8100



FAST TURNAROUND!

CUSTOM SHEET METAL FABRICATION FOR THE ROOFING INDUSTRY



Coping



Snap On Fascia



Galv. Box Gutter

Galvanized Steel - Pre-Painted Steel (Kynar) - Copper
EXPERTLY FABRICATED MADE TO ORDER FLASHINGS
708-544-3757 • Fax: 708-544-3761



if you can draw it, we can bend it!
WWW.JJSUPERIOR.COM
 4302 Warren Ave., Hillside, IL 60162



CRCA Associate Members

The Associate Members of the Chicago Roofing Contractors Association are a vital part of the association and actively support the activities. Besides their generosity, they are represented on the CRCA Board of Directors, Co-Chair the Membership and Trade Show Committees and serve on the Health & Safety, Contracts & Insurance, Industry Affairs, Program and Scholarship Committees.

4C's Spray Equipment Rental,			
Sales and Service	(717) 245-2711		
838 Coatings	(763) 972-9441		
A & D Products	(630) 668-1551		
A.C.T. Metal Deck Supply	(630) 978-7800		
AAAdvanced Building Products	(317) 993-3200		
ABC Supply Company, Inc.			
West Chicago	(630) 293-1222		
Addison	(630) 932-6653		
Alsip	(708) 396-1414		
Aurora	(630) 844-1700		
Gurnee	(847) 630-8094		
Joliet	(815) 723-9880		
Niles	(847) 588-0935		
AccuLynx	(608) 473-3800		
Adroit Marketing, Inc.	(630) 885-5447		
ADVANCED Architectural			
Sheet Metal & Supply	(231) 861-0050		
ALCO Products, LLC	(313) 823-7500		
APOC	(562) 423-6471		
Architectural Building Solutions, Inc.	(630) 402-9988		
Arvinyl Laminates, LP	(800) 278-4695		
Assurance Agency	(847) 463-7118		
Assured Partners Inc.	(630) 355-2077		
ATAS International, Inc.	(610) 395-8445		
Atlas Roofing Corporation	(800) 677-1476		
Barge Terminal Trucking, Inc.	(630) 499-5565		
Beacon			
Carol Stream	(630) 790-3400		
Arlington Hts.	(847) 357-0433		
Chicago / Ogden	(773) 530-1707		
Chicago / Pulaski	(773) 772-6500		
Des Plaines	(847) 795-9378		
Hickory Hills	(708) 599-9770		
Oak Forest	(708) 802-6123		
Wauconda	(847) 416-3202		
Berridge Mfg. Co.	(800) 488-7415		
Big Rock Supply	(630) 350-2300		
Bitec, Inc.	(501) 354-8585		
Bitumar USA Inc.	(410) 610-5953		
Blue Ridge Fiberboard, Inc.	(866) 850-8834		
Bone Roofing Supply, Inc.	(630) 628-8170		
Boral Roofing	(949) 756-1605		
Bostik Inc.	(312) 485-2845		
BPM Insurance	(816) 695-1306		
Carlisle Construction Materials/WIP	(630) 360-1306		
Carlisle SynTec	(800) 479-6832		
Castle Metal Products	(847) 806-4540		
Cedar Shake & Shingle Bureau	(604) 820-7700		
Certainteed Roofing Products	(630) 383-6741		
CHEM LINK Inc.	(800) 826-1681, x204		
Chicago Metal Supply & Fabrication	(773) 227-6200		
Chris Industries Inc.	(847) 729-9292		
Classic Gutter Systems LLC	(269) 665-2700		
CLEANWRAP Interior			
Protection Systems	(888) 597-3334		
CNA Insurance Lombard/Chicago	(630) 719-3000		
Columbia Green Technologies	(503) 964-3218		
Common Sense Solutions Inc.	(630) 379-0330		
Comprehensive Roofing Solutions Inc.	(815) 498-9485		
Comstruct Sales, LLC	(847) 922-3520		
Connor & Gallagher One Source	(708) 712-4793		
Cordeck	(262) 857-3000		
Cotney Construction Law, LLP	(813) 579-3278		
County Materials Corporation	(800) 289-2569		
Crissie Insurance Group	(847) 296-0655		
D & P Construction Co., Inc.			
Roll Off & Recycling	(708) 338-3534		
DA Sales & Marketing, Inc.	(630) 370-7747		
Dataforma, Inc.	(866) 764-9992		
DaVinci Roofscapes	(913) 599-0766		
DECRA Roofing Systems	(800) 258-9740, x189		
DERBIGUM Americas, Inc.	(708) 380-5045		
Detec Systems LLC	(855) 753-3832		
Disposal Alternatives	(617) 975-2000		
D-MAC Industries	(800) 878-3622		
DSP Insurance Services, Inc.	(847) 934-6100		
Durapax	(610) 579-9075		
Duro-Last Roofing, Inc. (Chicago)	(800) 248-0280		
Eagleview-Pictometry	(866) 659-8439, x5561		
East Lake Metals LLC	(219) 655-5526		
EcoStar LLC	(800) 211-7170		
Epilay Inc.	(310) 320-6300		
ERSystems	(800) 878-7876		
Everest Systems	(800) 575-8966		
FAKRO America, LLC	(630) 543-1010		
Firestone Building Products	(800) 428-4442		
FlashCo.	(866) 323-5274		
FT Synthetics In.	(604) 594-3493		
Gaco Western	(262) 951-0237		
GAF Materials Corporation	(630) 241 5372		
Garlock Chicago	(630) 521-9645		
Garth Building Products & Services Corp.	(708) 564-5137		
Garza Roofing Equipment and Supply	(630) 229-4440		
GCP Applied Technologies	(617) 498-4470		
Gemco Roofing & Building Supply	(708) 544-1444		
Geocel / Kool Seal	(800) 348-7615		
Georgia-Pacific Gypsum LLC	(404) 652-2592		
Giuffre Brothers Cranes	(708) 656-9200		
Greenrise Technologies	(615) 907-7460		
Gulfeagle Supply	(630) 773-0997		
H.B. Fuller Company - Roofing Products Group	(517) 841-7000		
Hapco Inc.	(800) 345-9353		
Hart & Cooley Roof Product Systems - Portals Plus, RPS & Milcor	(800) 624-8642		
Hendrick Phillips Salzman & Siegel, PC	(404) 522-1410		
Henry Company	(773) 412-9022		
HicksGas / Liberty Propane	(630) 806-9747		
Hines Supply	(847) 353-7700		
HLP Systems, Inc.	(847) 362-0777		
Houseworks Daylighting Solutions, LLC	(847) 729-0255		
Hover	(844) 754-6837		
Hub International Limited	(630) 468-5634		
Hunter Panels	(888) 746-1114		
IB Roof Systems	(800) 426-1626		
ICP Building Solutions Group	(330) 753-4585		
IKO	(312) 244-9932		
Industrial Cork Company, Inc.	(630) 832-2803		
Inland Coatings	(515) 993-4524		
INSULFOAM	(402) 624-6611		
Interior Protection Inc.	(630) 530-4920		
International Leak Detection, LLC	(866) 282-LEAK (5325)		
IR Analyzers / Vector Mapping	(800) 879-1964		
JJ Superior Metal, Inc.	(708) 544-3757		
Jobba Trade Technologies	(855) 633-3327		
Johns Manville Roofing Systems	(224) 325-2524		

CRCA Associate Members

Karnak Corporation	(732) 388-0300	Calumet City	(708) 891-2211	WindSmart LLC	(515) 314-1683
Kemper System	(716) 558-2971	Chicago/Belmont Ave.	(773) 499-7177	WOLFE LAW GROUP	(305) 989-6440
Kirby Fiberglass	(719) 547-3940	RM Bilrite LLC	(800) 877-8775	Worhouse, Inc.	(847) 621-2470
Kirsch BP/Sharkskin Roof		Rockwool	(289) 971-0894		
Underlayments	(805) 750-0084	Roofmaster Products Company	(800) 421-6174	Architects & Roof Consultants	
Lakefront Roofing Supply	(773) 509-0400	Runnion Equipment Company	(708) 447-3169	ARCON Associates, Inc.	(630) 495-1900
Lakeshore Recycling Systems	(773) 681-8811	S.J. Mallein & Assoc.	(630) 570-0301	Building Technology Consultants, Inc.	(847) 454-8800
Latino Workers Safety Center	(708) 449-9500	Safety Check, Inc.	(815) 475-9991	C.E. Crowley & Associates	(847) 662-8132
Leading Edge Safety	(816) 585-7722	Safety Rail Company LLC	(888) 434-2720	Century Roof Consultants	(847) 202-8500
Leister Technologies	(630) 760-1000	Schwab Group LLC	(630) 326-9444	Flood Testing Labs, Inc.	(773) 721-2200
Lift Works, Inc.	(630) 833-4626	Sentry Building Innovations	(877) 254-0788	Hutchinson Design Group	(312) 343-9595
Liftoff Crane Services LLC	(630) 800-6639	Sexton Properties R.P. LLC	(224) 212-1250	Illinois Roof Consulting Associates Inc.	(815) 385-6560
LiveRoof, LLC	(800) 875-1392	Sheet Metal Supply Ltd.	(847) 478-8500	INSPEC, Inc.	(847) 652-6617
Lomanco, Inc.	(800) 643-5596	Sievert Industries, Inc.	(815) 639-1319	Interstate Roof Systems	
R. M. Lucas Company	(773) 523-4300	Sika Sarnafil	(800) 532-5123 x7222	Consultants, Inc.	(847) 695-1460
Lurvey Supply	(262) 479-8369	Siplast	(800) 922-8800	K2N Crest	(630) 990-9595
MACK Construction Services, LLC	(773) 525-3411	Soprema, Inc.	(330) 334-0066	Kellermeyer Godfryt Hart, P.C.	(847) 318-0033
Malarkey Roofing Products	(503) 283-1191	Southwind RAS, LLC	(630) 233-5700 x119	Klein and Hoffman, Inc.	(312) 251-1979
Marathon Roofing Products/		Sutton Leasing	(847) 559-8300	Legat Architects	(630) 645-1906
MRP Supports, LLC	(800) 828-8424	TAMKO Building Products Inc.	(800) 641-4691	Mac Brady Associates, Inc.	(312) 550-1343
McElroy Metal, Inc.	(219) 879-0252	Tarco	(800) 365-4506	MTech Roofing Solutions LLC	(630) 777-8024
MEP Insulation Recycling	(317) 894-2763	The Estimating Edge, LLC	(561) 276-9100	Raths, Raths and Johnson, Inc.	(630) 325-6160
Mid-States Asphalt	(630) 730-1689	The Provant Group	(312) 888-4520	RCL Engineering Services	(847) 867-7093
Midwest Roofing Supply		Tilcor Roofing Systems	(916) 838-1940	SRI Consultants Inc.	(608) 831-5333
Naperville	(630) 637-0750	Tremco Inc.	(216) 292-5000	STR Building Resources LLC	(847) 652-6115
Schaumburg	(847) 241-2000	TRUFAST	(800) 443-9602	YA Engineering Services	(312) 919-8279
Waukegan	(847) 249-3328	Tuffwrap Installations, Inc.	(215) 256-6953		
Midwest Siding Supply, Inc.	(630) 897-2333	United States Gypsum	(312) 961-9935	Vacuuming	
Mule-Hide Products Co., Inc.	(815) 641-8548	VB Synthetics	(312) 664-3810	Dietz Vacuum Service, Inc.	(708) 301-9127
Novagard Solutions	(800) 380-0138	Velux America	(864) 941-4770	Ready Vac, Inc.	(847) 437-5771
NPC Colored Sealants	(708) 681-1040	Versico	(800) 992-7663	RK Hydro-Vac, Inc.	(800) 754-9376
OMG Roofing Products	(800) 633-3800	Walter Payton Power Equipment LLC	(708) 656-7700	Vac-It-All Services, Inc.	(314) 487-5600
Omni Ecosystems	(312) 337-3196	WickRight, Inc./365		Velocity Roof Vac Service Inc.	(630) 936-2421
Panasonic US	(201) 423-3154	Construction Tents	(312) 720-1467		
Petersen Aluminum Corporation	(800) 722-2523				
Polyglass U.S.A, Inc.	(847) 431-6005				
Prairie State Exterior Products	(708) 754-9339				
Pro Fastening Systems Inc.	(847) 577-7185				
Pro Lightning Protection	(262) 925-7199				
Progressive Materials	(630) 488-9277				
Quarrix Building Products	(800) 438-2920				
Raindrop Gutter Guard	(800) 816-0199				
RainTrade Corporation	(847) 283-0006				
Raptor Synthetic Underlayments	(317) 202-8200				
RESISTO	(855) 227-7850				
RHP Risk Management Inc.	(773) 867-6004				
Richards Building Supply Company					
Corporate	(773) 586-7777				
Joliet	(815) 725-2458				

CRCA welcomes the following new members since the Spring 2020 CRCA Today Issue!

Associate Members:

RHP Risk Management, Inc.
Roof Consultant Members:
ARCON Associates, Inc.
RCL Engineering Services

Contractor Members:

Economy Roofing
Tori Construction LLC

To learn more about these firms, visit www.CRCA.org and visit the member list! To learn more about CRCA Membership benefits, contact info@crca.org today!

SPANISH

FALL PROTECTION TRAINING

WE'RE THE PLACE!



LWSC

Multilingual Safety Training

888-595-5972

Free OSHA Compliant Certificate Classes

English, Spanish or Polish!

- Excavation Safety
- Chemical Safety (HazCom)
- Silica Hazard Awareness
- Respiratory Protection
- Protecting yourself against COVID-19 in the workplace

For more information, please visit lwsc.org

This material was produced under grant number Susan Harwood Grant # SH-05165-SH9 during Grant Year 2019 from the Occupational Safety and Health Administration, U.S. Department of Labor. It does not necessarily reflect the views or policies of the U.S. Department of Labor, nor does mention of trade names, commercial products, or organizations imply endorsement by the U.S. Government.



REPRESENTING THE ROOFING INDUSTRY



SERVING ROOFING PROFESSIONALS NATIONWIDE

CotneyCL.com | 312.971.5965

Attorney Trent Cotney

5600 N River Road PMB #29, Suite 800, Rosemont, IL 60018